



**Tree Survey, Arboricultural Impact Assessment  
Preliminary Arboricultural Method Statement & Tree Protection Plan  
In Accordance with BS 5837:2012**

Proj. No <b>8100</b>	<b>Hotel Felix, Whitehouse Lane, Huntingdon Road, Girton, Cambridgeshire, CB3 0LX</b>		
Client:		Cassel Hotels (Cambridge) Limited	
Date of Report:	23/02/2021	Revision:	Original

# **Tree Survey, Arboricultural Impact Assessment, Preliminary Arboricultural Method Statement & Tree Protection Plan – In Accordance with BS 5837:2012**

## **Summary**

The purpose of this report is to provide a preliminary consideration of the arboricultural implications created by the proposed development. In accordance with the feasibility and planning sections of BS5837:2012 “*Trees in relation to design, demolition and construction – Recommendations*”, trees deemed to be within the influencing distance of the projected construction have been evaluated for quality, longevity, and initial maintenance requirements. Where trees do not have to be removed for health and safety reasons, a detailed and objective assessment has been made of the consequences of the intended layout.

In this circumstance it is intended to demolish the existing hotel and develop the site for a new residential care home with associated access and landscaping . As a result, seventy-one individual trees, seven groups of trees, two areas of trees and ten hedges were inspected. The arboricultural related implications of the proposal are as follows:

- 1 In addition to trees which require felling irrespective of development, it is necessary to fell eleven individual trees and four landscape features in order to achieve the proposed layout. Additionally, two trees require minor surgery to permit construction space or access.
- 2 It is proposed to move up to nine trees using a vehicle mounted tree spade in order to achieve the proposed layout and landscaping scheme. Should any of the moved trees fail after being replanted they shall be replaced with a suitable replacement specimen.
- 3 Two trees have been identified for removal irrespective of any development proposals.
- 4 The alignment of a bike store encroaches within the Root Protection Area of trees that are to be retained. In view of this, careful consideration must be given to foundation design as discussed at item 4.4.2.
- 5 The alignment of the main care home building does not encroach within the Root Protection Areas of any trees that are to be retained. In view of this, and as assessed in accordance with BS5837:2012, no specialist foundation designs or construction techniques will be required to prevent damage to tree roots. Specialist foundations may still be required for other reasons, including mitigating the influencing distance of tree roots, subject to expert advice from a structural engineer.
- 6 The alignment of proposed footpaths and access areas encroach within the Root Protection Areas of fifteen items that are to be retained, but given the use of modern no dig construction techniques this is not considered to be a substantial issue.



- 7 The alignment of parking and access areas nominally intrudes within the Root Protection Areas of eight items to be retained. This has only minor influence on the Root Protection Areas and as such it is considered appropriate to undertake linear root pruning, thus obviating the need for specialist no dig construction techniques at these locations.
- 8 This report recommends that specialist advice is obtained by expert practitioners in other disciplines. Such input should always be sought prior to the submission of this report in support of a planning application in order to demonstrate that the techniques and methods hereby proposed are achievable. In this particular circumstance it is necessary to contact the following:
  - Structural Engineer (foundation design, item 4.4.1 and 4.4.2)
  - Civil Engineer (no dig surfacing, item 4.4.6)
- 9 All trees and landscape features that are to remain as part of the development should suffer no structural damage provided that the findings with this report are complied with in full. This includes ensuring that protective fencing is erected as detailed at items 4.6 and 5.1 of this report.
- 10 Post Planning Permission – Subject to achieving Planning Permission, a detailed Arboricultural Method Statement and Tree Protection Plan will be required. This will include the following: fencing type, ground protection measures, no dig surfacing, access facilitation pruning specification, phasing and an extensive auditable monitoring schedule.

Given the above, there are no overt or overwhelming arboricultural constraints that can be reasonably cited to preclude the proposed construction.



# Contact Details

Client – Cassel Hotels (Cambridge) Limited			
<b>Address</b> 4th Floor, 192 Sloane Street, London SW1X 9QX	<b>Contact</b> Mr James Gant	<b>E-mail:</b>	<a href="mailto:james.gant@kyn.life">james.gant@kyn.life</a>

Local Planning Authority – South Cambridgeshire District Council			
<b>Address</b> South Cambridgeshire Hall Cambourne Business Park Cambourne Cambridgeshire CB3 6EA	<b>Trees Officer</b> Ms Miriam Hill	<b>Tel:</b> <b>E-mail:</b>	01954 713405 <a href="mailto:planning.trees@scambs.gov.uk">planning.trees@scambs.gov.uk</a>

Arboricultural Consultant – Hayden's Arboricultural Consultants Limited			
<b>Address</b> 5 Moseley's Farm Business Centre Fornham All Saints Bury St Edmunds Suffolk IP28 6JY	<b>Report Author:</b> Mr Stephen Holyland	<b>Tel:</b> <b>E-mail:</b>	01284 765391 <a href="mailto:info@treesurveys.co.uk">info@treesurveys.co.uk</a>



# Contents

- 1.0 Introduction**
- 2.0 The Site**
- 3.0 Tree Survey**
- 4.0 Arboricultural Impact Assessment**
- 5.0 Design Advice, Preliminary Arboricultural Method Statement & Tree Protection Plan**
- 6.0 Recommendations**
- 7.0 Limitations & Qualifications**
- 8.0 References**
- 9.0 Appendices**



# 1.0 Introduction

## 1.1 Terms of Reference

1.1.1 Hayden's Arboricultural Consultants Limited has been commissioned by Meedhurst Project Management on behalf of their clients Cassel Hotels (Cambridge) Limited to prepare a Tree Survey, Arboricultural Impact Assessment, Preliminary Arboricultural Method Statement and Preliminary Tree Protection Plan for the existing trees at Hotel Felix, Whitehouse Lane, Huntingdon Road, Girton, Cambridgeshire, CB3 0LX.

1.1.2 The site survey was carried out on 15/04/2020. The relevant qualitative tree data was recorded in order to assess the condition of the existing trees, their constraints upon the prospective development and the necessary protection and construction specifications required to allow their retention as a sustainable and integral part of the completed development.

1.1.3 Information is given on condition, age, size and indicative positioning of all the trees, both on and affecting the site. This is in accordance with the British Standard 5837:2012 *Trees in relation to design, demolition and construction - Recommendations*.

## 1.2 Scope of Works

1.2.1 The survey of the trees and any other factors are of a preliminary nature. The trees were inspected on the basis of the Visual Tree Assessment (VTA) method as developed by Mattheck and Breloer (1994). The trees were inspected from ground level with no climbing inspections undertaken. It is not always possible to access every tree and as such some measurements may have to be estimated. Trees with estimated measurements are highlighted in the schedule of trees. No samples have been removed from the site for analysis. The survey does not cover the arrangements that may be required in connection with the removal of existing underground services.

1.2.2 Whilst this is an arboricultural report, comments relating to non arboricultural matters are given, such as built structures and soil data. Any opinion thus expressed should be viewed as provisional and confirmation from an appropriately qualified professional sought. Such points are clearly identified within the body of the report.

1.2.3 An intrinsic part of tree inspection in relation to development is the assessment of risk associated with trees in close proximity to persons and property. Most human activities involve a degree of risk with such risks being commonly accepted, if the associated benefits are perceived to be commensurate. In general, the risk relating to trees tends to increase with the age of the trees concerned, as do the benefits. It will be deemed to be accepted by the client that the formulation of the recommendations for all tree management will be guided by the cost-benefit analysis (in terms of amenity), of the tree work.

## 1.3 Documentation

1.3.1 The following documentation was provided prior to the commencement of the production of this report;

- Email of instruction from Mr Mark Kempson on the 8th April 2020
- Definition of site boundary
- Description of requirements/deadlines
- Topographical survey/map
- Proposed site layout



## 2.0 The Site

### 2.1 Overview

2.1.1. The site is Hotel Felix, Whitehouse Lane, Girton, Cambridgeshire, CB3 0LX.

### 2.2 Soils

2.2.1 The soils type commonly associated with this site are freely draining lime rich loams. They are of moderate fertility and mainly support herb-rich chalk and limestone pastures, and lime-rich deciduous woodland type habitats. This soil type constitutes approximately 3.7% the total English land mass.

2.2.2 The data given was obtained from a desk top study which provides indications of likely soil types. By definition, this information is not comprehensive and therefore any decisions taken with regards the management, usage or construction on site should be based on a detailed soil analysis.

2.2.3 Further to item 2.2.2, this report provides no information on soil shrinkability. It may be necessary for practitioners in other disciplines (e.g. engineers considering foundation design) to obtain this data as required.

### 2.3 Statutory Tree Protection

#### 2.3.1 Tree Preservation Order(s)

The local planning authority South Cambridgeshire District Council have deemed it appropriate to provide statutory protection to trees on and neighbouring this site through the serving of a Tree Preservation Order (TPO), Ref no TPO 27/03/SC. The effect of this on the owners, managers or any persons wishing to undertake work on preserved trees is to require them to obtain written permission from South Cambridgeshire District Council prior to actioning any surgery or felling etc. The purpose of this process is to try to ensure that the works are appropriate, proportionate, and in keeping with the long-term aims of the TPO (as expressed in the original TPO statement) but, given that trees are living organisms, and the locality within which they are set is liable to change, it is often the case that local planning authority decisions relating to TPO applications require regular review to reflect the current situation rather than the historical perspective of the original date of protection.

There are certain circumstances where written permission from the local planning authority may not be necessary before undertaking works. These include;

- Making a tree safe if it is an imminent threat to people or property.
- Removing dead wood, or a dead tree.

Owners, managers or any persons wishing to undertake work as an exemption to the written permission process **are required** to provide the local planning authority with 5 days' notice prior to attending to a tree which they deem as being dead or dangerous; unless such works are required in an emergency. It is the tree owner's responsibility to provide proof that the tree was indeed dead or dangerous should this exception be challenged; hence, it is advisable always to request an inspection by the Local Planning Authority prior to carrying out such operations. Furthermore, and even in the event of an emergency situation, there is still a duty to notify the local planning authority that work has been completed including supplying an explanation of the necessity. Failure to comply with the requirements of TPO legislation can lead to a maximum fine of up to £20,000 per tree in the Magistrates Court. Fines in the Crown Court are unlimited.



This information was sourced using the Local Planning Authority's Online Mapping System (as instructed by them) and to our best knowledge was current and accurate at the time the information was accessed. We would advise it prudent that before any tree work commences, this is checked directly with the Local Planning Authority to confirm that their online mapping system is definitive.

### 2.3.2 Felling Licence

All trees within the United Kingdom are protected under the Forestry Acts. In general, anyone felling more than 5 cubic metres of timber in any calendar quarter requires a Felling Licence from the Forestry Commission. There are exemptions however and these are as follows:-

A Felling Licence is not required in the following instances:

- To fell trees in a garden, an orchard, a churchyard, or a designated open space (Commons Act 1899).
- To carry out surgery operations such as pruning, reduction, dead wooding or pollarding.
- To fell less than 5 cubic metres in a calendar quarter. (Please note that not more than 2 cubic metres in a calendar quarter may be sold).
- To fell trees that are 8 centimetres or less in diameter when measured 1.3 metres from the ground. Trees removed for thinning may have a diameter of up to 10 centimetres and trees managed under a coppice regime may have a diameter of up to 15 centimetres.
- To fell trees previously approved for removal under a Dedication Scheme, or where Detailed Planning Permission has been granted.

Substantial fines exist for not complying with the requirements of a Felling Licence.

### 2.3.3 Hedgerow Regulations and Inclosure Act

Certain hedgerows within the United Kingdom are protected under The Hedgerow Regulations 1997. The regulations apply to any hedgerow growing in, or adjacent to, any common land, protected land (local nature reserves and SSSIs), or land used for agriculture, forestry or the breeding or keeping of horses, ponies or donkeys, if it: (a) has a continuous length of, or exceeding 20m; or (b) it has a continuous length of less than 20m and, at each end, meets another hedgerow. The regulations do not apply to hedgerows within the curtilage of, or marking a boundary of the curtilage of, a dwelling house.

Anybody wishing to remove or destroy a hedge must apply to their Local Planning Authority (LPA) for consent. Substantial fines exist for not complying with the requirements The Hedgerow Regulations.

Older hedges could be protected by old Inclosure Acts. These Acts may require that hedges are retained and managed in perpetuity.

It is recommended professional legal advice be sought before removing hedgerows to determine whether the hedgerow might be protected by the Inclosure Act. Details of the Inclosures Act are held by the Local Records Office.





## 3.0 Tree Survey

- 3.1 As part of this survey a total of seventy-one individual trees, seven groups of trees, two areas of trees and ten hedges have been identified. These have been numbered T001 – T071, G001 – G007, A001 – A002 and H001 – H010 respectively.
- 3.2 A topographical survey was provided which showed the position of the trees on site. It should be noted however that topographical surveys are not always comprehensive and sometimes it is considered appropriate to record details of trees and landscape features omitted from or beyond the scope of the plan. If this circumstance occurs, the location of the individual tree or landscape feature is estimated. The position of each tree is shown on the attached drawing no. 8100-D-AIA.
- 3.3 In order to provide a systematic, consistent and transparent evaluation of the trees included within this survey, they have been assessed and categorised in accordance with the method detailed in item 4.3 of *BS 5837:2012 "Trees in Relation to Design, Demolition and Construction - Recommendations"*. For further information, please see the attached Explanatory Notes.
- 3.4 The detailed assessment of each tree and its work requirements with priorities are listed in the attached Schedule of Trees.
- 3.5 Several items would benefit from tree surgery or additional investigation, be it for health and safety, cultural, aesthetic, or structural reasons as detailed in the attached Schedule of Trees. Including the trees recommended for felling, the items requiring the **most urgent** intervention are as follows:

Within six months:

G003	Remove all deadwood.
T014	Install non-invasive brace OR fell and replant.
T021	Fell and replant.
T060	Remove all deadwood.

- 3.6 Over and above the general and prudent recommendation that all trees are inspected on an annual basis, the following items have been identified as requiring enhanced monitoring to assess any changes in faults and weaknesses etc as detailed in the Schedule of Trees:

T012	Monitor annually for further deterioration.
------	---

- 3.7 In accordance with item 4.2.4 (c) of BS 5837:2012, the items inspected and detailed within this report have been selected for inclusion due to the likely influence of any proposed development on the trees, rather than strictly adhering to the curtilage of the site. However, it must be understood that there may be trees beyond the site and not included in this survey which may exert an influence on the development. Where works for cultural, health and safety, quality of life, or development purposes have been recommended on trees outside the ownership of the site, these can only progress with the agreement of the owner, except where it involves portions of the trees overhanging the boundary.



## 4.0 Arboricultural Impact Assessment

### 4.1 The Proposal

- 4.1.1 The proposal is to demolish the existing hotel and develop the site for a new residential care home with associated access and landscaping within the curtilage of the site.

### 4.2 Access

- 4.2.1 Site access is encumbered by the theoretical Root Protection Area (RPA) of the following retained trees – T012, T013 and T014. In this case the RPA is safeguarded by existing hard surfaces and therefore, and from a purely arboricultural perspective, it will not be necessary to install a proprietary temporary load bearing road to protect tree roots. As part of the construction phase, careful phasing will be required when the new access alignment is required to be installed.

### 4.3. Demolition

- 4.3.1 Demolition of existing structures affects the theoretical RPA of the following retained tree – T070. In order to prevent damage to this specimen works must only be completed with appropriate machinery or by hand within the calculated RPA and may only commence once protective fencing has been erected. In the proximity of the retained trees, all walls and material must be demolished inwards into the footprint of the building and away from the stems (often referred to as “top down, pull back”). Additionally, all plant and vehicles engaged in demolition should either operate outside the theoretical RPA, or should run on a temporary load bearing surface to protect the underlying soil structure. All foundations or hard surfaces within the theoretical RPA are to be broken out with extreme care, either manually or with a breaker (operating outside the RPA, or on the temporary load bearing surface).

### 4.4 Construction

- 4.4.1 Construction of foundations or structural supports for the proposed new care home do not encroach within the Root Protection Area (RPA) of any trees to be retained. Therefore from an arboricultural perspective, no specialised construction or foundation techniques will be required to protect tree roots. However, dependent on the soil type, species and topography, trees may have an influence on the soil beyond their calculated RPA. Given the proximity of the proposed construction to the trees to be retained, it is recommended that a Structural Engineer is consulted to assess the implications of the tree retention on the required foundation design.
- 4.4.2 Installation of a proposed bike store encroaches within the RPA of the following item to be retained – G003. Provided that these work with finished levels and required load bearings without cutting into the ground, the main surface should be attended to by the use of no dig construction methods. In the detailed Arboricultural Method Statement & Tree Protection Plan, Hayden’s Arboricultural Consultants will supply a sample design of no dig surfacing. However, the exact specification (adhering to the principles of the sample design) must be designed by a Civil Engineer who can confirm that the finished levels and load bearings are achievable with this type of design without cutting into the ground. The bike store frame structure will then be supported from either mini screw piles or concrete pads installed by hand. The bike store should be constructed as a last phase of development, with the area initially protected with protective fencing at the edge of the RPA for the main phases of construction.



- 4.4.3 It is proposed to construct replacement hard surfaces in the RPA of T014, T024 and T033. In this situation hard surfacing already exists. If the process involves top dressing the existing surface there will be no implications for the retained trees. However, if the proposal involves removing the existing hard surface, this must be completed under arboricultural supervision and by hand, or with appropriate lightweight machinery. The new hard surfacing must be of similar construction to that which has been removed to prevent any adverse impact on the RPA, and must include a barrier of sharp sand if roots are exposed during the lifting of the original surface.
- 4.4.4 Installation of a replacement curb line encroaches within a small portion of the RPA of the following tree to be retained – T014. Given the previous presence of an existing curb it is only considered a minor intrusion at this location. It may be necessary to undertake precautionary linear root pruning as part of the access facilitation pruning (AFP) works.
- 4.4.5 Construction of new hard surfaces encroach within a small portion of the RPA of the following trees to be retained – G003, G006, T010, T024, T035, T044 and T070. Given the minor extent of the intrusion at these locations it is considered appropriate to undertake linear root pruning as part of the access facilitation pruning (AFP) works. This operation will obviate the need for no dig construction methods in these situations.
- 4.4.6 Installation of new hard surfaces for vehicular access and footpaths encroach within the RPA of the following items to be retained – A002, G003, T004, G005, H006, G007, H009, T033, T035, T044, T045, T046, T060, T061, T067 and T070. Provided that these work with finished levels and required load bearings without cutting into the ground, the surfaces should be attended to by the use of no dig construction methods. In the detailed Arboricultural Method Statement & Tree Protection Plan, Hayden's Arboricultural Consultants will supply a sample design of no dig surfacing. However, the exact specification (adhering to the principles of the sample design) must be designed by a Civil Engineer who can confirm that the finished levels and load bearings are achievable with this type of design without cutting into the ground. In order to protect the RPA of the affected trees, these areas should be constructed as a first phase of the development – i.e. immediately after the necessary tree surgery has been completed and protective fencing erected. It is recognised that the final top dressing of the hard surfaces could be added at the completion of the project, however during the construction phase the permeable surface must be sealed and protected to prevent contamination and compaction. Whatever method of sealing and protection is used, this must be removed at the completion of construction to allow for moisture penetration and gaseous exchange. Alternatively, the protective fencing could be re-sited to the edge of the RPA of these trees and the no dig construction completed as a final phase of development.
- 4.4.7 Excavation and soil re-modeling is not shown to encroach within the RPA of any retained trees. Therefore, no adverse arboricultural implications are expected.

#### 4.5 Implications of Sloping Ground

- 4.5.1 The arboricultural implications of the proposed structures are based on an assumption that because there are no significant existing slopes on site, level changes will not occur within the RPA of trees that are shown to be retained.



#### 4.6 Requirement for Tree Barrier Fencing

4.6.1 Prior to the commencement of demolition or construction and immediately after the completion of the necessary tree surgery and felling work, protective fencing will be erected on site. This must be fit for purpose (including any ground protection if necessary) in full accordance with the requirements of BS 5837:2012 and positioned as shown on the attached Preliminary Arboricultural Impact Assessment & Tree Protection drawing. Full details of fencing will be supplied by Hayden's Arboricultural Consultants in the detailed Arboricultural Method Statement & Tree Protection Plan.

#### 4.7 Compound

4.7.1 The site provides adequate internal space to locate a construction compound outside the RPA of any trees and landscape features that are to be retained.

#### 4.8 Phasing

4.8.1 The proposal involves the integration of a number of complex aspects that affect tree protection (e.g. – but not exclusively – access, movement of materials and the installation of services). For this reason, the project must be carefully phased to ensure the highest level of protection for retained trees at all times. As part of the detailed Arboricultural Method Statement & Tree Protection Plan, Hayden's Arboricultural Consultants will produce an in-depth phasing recommendation to cover the major operations on site as they affect retained trees.

#### 4.9 Monitoring

4.9.1 In accordance with item 6.3 of BS 5837:2012, the site and associated development should be monitored regularly by a competent Arboriculturalist to ensure that the arboricultural aspects of the planning permission are complied with. As part of the detailed Arboricultural Method Statement & Tree Protection Plan, Hayden's Arboricultural Consultants will produce an extensive auditable monitoring schedule to assess the progress of key site events/activities.

#### 4.10 Cultural Implications for Retained Trees

4.10.1 Cultural Implications for retained trees are low. Details of specific works are listed in the attached Schedule of Works to Permit Development.

#### 4.11 Landscape Implications

4.11.1 In addition to trees and landscape features necessitating removal for health and safety, cultural or quality of life reasons, (as detailed in the attached Schedule of Works - Irrespective of Development) the items listed in the table below require felling or moving by a tree spade, to permit the proposed development to proceed:

Feature No	Reason for Removal	BS * Category	Visual Amenity Assessment*
A001	To enable construction of parking area.	C	Moderate
H001	To enable construction of parking area and access.	C	Moderate
H007	To enable construction of parking area and access.	C	Moderate
H010	To enable construction of care home building and landscaping.	C	Moderate



T001	To enable construction of parking area.	C	Moderate
T002	To enable construction of parking area.	C	Moderate
T003	To enable construction of parking area.	C	Moderate
T023	To enable new entrance with footpath.	B	High
T027	To enable construction of parking area.	B	Moderate
T028 (tree to be moved with tree spade)	To enable construction of access.	B	Moderate
T029 (tree to be moved with tree spade)	To enable construction of access.	B	Moderate
T033	To enable construction of access.	B	Moderate
T035	To enable construction of access.	B	Low
T043 (tree to be moved with tree spade)	To enable construction of footpath.	B	Moderate
T049 (tree to be moved with tree spade)	To enable construction of access area.	B	Moderate
T050	To enable construction of access area.	C	Moderate
T051 (tree to be moved with tree spade)	To enable construction of care home building and landscape area.	B	Moderate
T052 (tree to be moved with tree spade)	To enable construction of care home building and landscape area.	B	Moderate
T053 (tree to be moved with tree spade)	To enable construction of care home building and landscape area.	B	Moderate
T054 (tree to be moved with tree spade)	To enable construction of care home building and landscape area.	B	Moderate
T055	To enable construction of care home building and landscape area.	B	Moderate
T056	To enable construction of care home building and landscape area.	C	Moderate
T057	To enable construction of care home building and landscape area.	C	Moderate
T058	To enable construction of care home building and landscape area.	C	Moderate
T059	To enable construction of care home building and landscape area.	C	Moderate
T071	To enable construction of care home building.	A	Moderate

\* Please see definitions in the Explanatory Notes attached to this report.



#### **4.12 Post Development Implications**

- 4.12.1 No adverse arboricultural implications are considered reasonably foreseeable for the trees that remain provided that the recommendations of this report are complied with in full.
- 4.12.2 Due to the dynamic nature of trees and their interaction with the environment, their health and structural integrity is liable to change over time. Because of this it is recommended that all trees on or adjacent to the site be inspected on an annual basis.
- 4.12.3 As stated in BS 5837:2012, regular maintenance of newly planted trees is of particular importance for at least three years during the critical post-planting period and might, where required by site conditions, planning requirements or legal agreement, be necessary for five years or more. Therefore, the designer of the new landscaping should, in conjunction with the landscape design proposals, prepare a detailed maintenance schedule covering this period, and appropriate arrangements made for its implementation.

### **5.0 Design Advice, Preliminary Arboricultural Method Statement & Tree Protection Plan**

#### **5.1 Securing of Tree Structure and Root Protection Areas (RPA)**

- 5.1.1 The trees to be retained will be protected by the use of stout barrier fencing erected in the positions indicated on the attached Preliminary Arboricultural Impact Assessment & Tree Protection drawing no. 8100-D-AIA. This fencing will be in accordance with the requirements of BS 5837:2012 including any necessary ground protection.
- 5.1.2 All fencing provided for the safeguarding of trees will be erected prior to any demolition or development commencing on the site, therefore ensuring the maximum protection. This fencing, which must have all weather notices attached stating "Construction Exclusion Zone – No Access" will be regarded as sacrosanct and, once erected, will not be removed or altered without the prior consent of the Local Planning Authority.
- 5.1.3 Where footpaths, access drives, or parking bays are constructed within the RPA of retained trees, careful attention will be paid to the type of surface treatment used in these areas, details of which are given in item 5.8, below. If possible, these should be installed as a final phase of the project, thereby protecting the RPA throughout the major construction phase of the proposed development.
- 5.1.4 Where fencing is impractical, consideration must be given to other forms of effective above ground tree structure protection. An example of this would be a combination of Barksavers to secure the stems and a temporary load bearing surface to shield the ground.

#### **5.2 Location of Site Office, Compound and Parking**

- 5.2.1 The position of the office, compound and parking will be agreed in writing with the Local Planning Authority prior to commencement of any permitted development works. Any proposed re-location of these items through the various phases of development will be agreed prior to re-siting with the Local Planning Authority.



### **5.3 On Site Storage of Spoil and Building Materials**

- 5.3.1 Prior to and during all construction works on site, no spoil or construction materials will be stored within the RPA of any tree on, or adjacent to the site, even if the proposed development is to be within the RPA. This is to reduce to a minimum the compaction of the roots of the trees. Details of the RPA for each tree where no spoil or building materials will be stored are indicated on the attached Preliminary Arboricultural Impact Assessment & Tree Protection drawing no. 8100-D-AIA. Any encroachment within this protected area will only be with the prior agreement of the Local Planning Authority.
- 5.3.2 Any facilities for the storage of oils, fuels or chemicals shall be sited on impervious bases and surrounded by impervious bund walls. The volume of the bund compound shall be at least equivalent to the capacity of the tank plus 10%. If there is a multiple tankage, the compound shall be at least equivalent to the capacity of the largest tank, or the combined capacity of interconnected tanks, plus 10%. All filling points, vents, gauges and sight glasses shall be located within the bund. The drainage system of the bund shall be sealed with no discharge to any watercourse, land or underground strata. Associated pipe-work shall be located above ground and protected from accidental damage. All filling points and tank overflow pipe outlets shall be detailed to discharge downwards into the bund.
- 5.3.3 All material storage facilities and work areas must consider the effects of sloping ground on the movement of potentially harmful liquid spillages towards or into protected areas.

### **5.4 Programme of Works**

- 5.4.1 All tree surgery works, once approved by the Local Planning Authority, will be carried out prior to any other site works. Once completed, the proposed protective fencing will be erected along the lines indicated above. All of this will be carried out prior to commencement of any development works on the site. Outline details of the proposed programme are given in the Design and Construction and Tree Care flow chart attached (Appendix G-1).

### **5.5 Tree Surgery**

- 5.5.1 All tree work will be agreed with the Local Planning Authority and will be carried out in line with BS 3998:2010 (Recommendations for Tree Works). An arboricultural contractor approved by the Local Planning Authority will carry out the work. Any alterations to the proposed schedule of works will be agreed with the Local Planning Authority prior to commencement of works.

### **5.6 Levels**

- 5.6.1 Other than for any specific exception which may be referred to at item 4.0, no alterations to soil levels within the RPA of retained trees are envisaged. However, if it is necessary for these to occur, appropriate measures must be taken to prevent or minimise any detrimental effects on the affected root systems as detailed in 5.6.2 and 5.6.3 below.
- 5.6.2 If it is necessary to excavate so close to trees that roots greater than 50mm diameter are likely to be encountered, particular care will be taken to avoid damage. Excavation in these areas will be undertaken by hand or using an air spade, avoiding any damage to the bark. The roots will be surrounded with sharp sand prior to the replacing of any soil or other material in the vicinity.



5.6.3 If it is necessary to raise levels, it is essential that adequate supplies of water and oxygen pass through the soil to the trees' roots. Therefore, where necessary, a granular material will be used which will not inhibit gaseous diffusion. Possible options are no-fines gravel, cobbles or, Type 2 road-stone. All hard surfaces will be of suitable specification to allow such gaseous diffusion, e.g. brick pavers.

## 5.7 Services

5.7.1 At the time of writing this report, no details on proposed services were available. However, the following principles should be adhered to when planning for their installation.

5.7.2 It is proposed that all underground service runs will be placed outside the RPA of the trees on or adjacent to the site. Where it is not possible to do this, the proposed length infringing the RPA will be hand dug 'broken trenches' (NJUG 4 paragraph 4) to ensure the maximum protection of the trees' roots. The trenches may also be excavated using an air spade, or trenchless technology can be employed if this methodology is considered appropriate by the relevant service company (thus allowing services to pass below and through the roots without the need for traditional excavation). If it is necessary to cut any small roots as part of any of these processes, they should be severed in such a way as to ensure that the final wound is as small as possible and free from ragged, torn ends.

5.7.3 All routes for overhead services will aim to avoid the trees. Where this is not possible, any tree work will be agreed prior to commencement with the Local Planning Authority.

5.7.4 All service providers (Statutory Authorities) will be consulted prior to commencement of works with the aim of minimising the number of service runs on the site.

5.7.5 All service runs/trenches where they encroach within the RPA of retained trees will be agreed with the Local Planning Authority prior to commencement of works.

## 5.8 Hard Surface Types & Construction within the Root Protection Area

5.8.1 Where it is necessary to construct footpaths, driveways, non-adoptable roads, and other hard surfaces within the RPA as calculated in accordance with BS 5837:2012 (item 4.6.1), it is proposed that the design will comply with the 'no-dig' principles of the Arboricultural Advisory Information Services (AAIS) Practice Note 12 "*Through the Trees to Development*" - the only difference being that instead of a geo-grid, a geo-textile base is provided, and the no-fines road stone is incorporated in and retained by a geo-web cellular confinement system. Given the individual requirements of each site, it is essential that a specialist engineer is consulted to specify the construction detail. Where it is necessary to remove any existing hard surface, or lower the ground level within the RPA, this may expose roots. This operation must be undertaken using hand tools or an air spade. Any roots found should be treated with the greatest care and surrounded by sharp sand to provide a level base. Please note that 'no-dig' surfaces are not always considered acceptable for adoption.

5.8.2 Where it is shown that the construction of a boundary wall or dwelling encroaches within the RPA of a retained tree, the foundations of the wall or dwelling will be designed in such a manner so as to minimise the detrimental effect of the construction on the tree's roots.





In these situations, any excavations within the RPA of an affected tree will only be undertaken following exploration of the existing root system with an air spade (or by hand digging if soil conditions preclude) and the necessary root pruning undertaken to allow excavation without unnecessary pulling and tearing of the roots to be retained. This will ensure minimal damage to tree roots where pad and beam or cantilever foundations are considered appropriate. Should a piling rig be required to create piles, any access facilitation pruning or felling necessary to allow access must be undertaken before the commencement of works and only with prior consent of the Local Planning Authority.

- 5.8.3 If boundary fencing is to be erected within the RPA of retained trees, it is proposed that the fence posts will be secured by the use of “Met-Posts” or similar design in order to keep the disturbance and damage of the roots of the trees to a minimum.

## 5.9 Reporting and Monitoring Procedures

- 5.9.1 In accordance with item 6.3 of BS 5837:2012, the site and associated development should be monitored regularly by a competent arboriculturalist to ensure that the arboricultural aspects of the planning permission (e.g. the installation and maintenance of protective measures and the supervision of specialist working techniques) are implemented. Furthermore, regular contact between the Site Manager and the Arboriculturalist allows them to effectively deal with and advise on any tree related problems that may occur during the development process. This system should be auditable. Should any issues arise during the arboricultural monitoring of the development the Arboriculturalist will contact the Local Planning Authority and appropriate action taken only with the prior permission of Cassel Hotels (Cambridge) Limited and the Local Planning Authority.

## 6.0 Recommendations

- 6.1 It is recommended that the measures outlined in this report are implemented in full to provide retained trees with the highest level of protection during the process of demolition and construction.
- 6.2 Subject to achieving Planning Permission, it is recommended that a detailed Arboricultural Method Statement & Tree Protection Plan should be provided. This will include the following: fencing type, ground protection measures, no dig surfacing, access facilitation pruning specification, project phasing and an extensive auditable monitoring schedule.
- 6.3 Tree surgery should be completed as detailed in the Schedule of Trees. Where this has been identified for reasons other than to permit development, this work should be completed within the advised timescales irrespective of any development proposals.
- 6.4 The tree surgery works proposed as part of this Survey are recommended to mitigate any identified problems that may be caused by trees in close proximity to the proposed development. To this end, should these recommendations be overruled, this Survey stands as the opinion of Hayden’s Arboricultural Consultants Limited, and therefore any damage or injury caused by trees recommended by this practice for felling or tree surgery works, to which the proposed schedule of works has been altered or the tree has been requested to be retained by the Local Planning Authority, cannot be the responsibility of this practice.



## 7.0 Limitations & Qualifications

Tree inspection reports are subject to the following limitations and qualifications.

### General exclusions

Unless specifically mentioned, the report will only be concerned with above ground inspections. No below ground inspections will be carried out without the prior confirmation from the client that such works should be undertaken.

The validity, accuracy and findings of this report will be directly related to the accuracy of the information made available prior to and during the inspection process. No checking of independent third-party data will be undertaken. Hayden's Arboricultural Consultants Limited will not be responsible for the recommendations within this report where essential data are not made available or are inaccurate.

This report will remain valid for one year from the date of inspection subject to the recommendations specified within being adhered to. It must also be appreciated that recommendations proposed within this report may be superseded by extreme weather, or any other unreasonably foreseeable events.

However, if any additional alterations to the property or soil levels are carried out and/or further tree works undertaken other than specified within the report, it will become invalid and a new tree inspection strongly recommended.

It will be appreciated, and deemed to be accepted by the client and their insurers, that the formulation of the recommendations for the management of trees will be guided by the following: -

1. The need to avoid reasonably foreseeable damage.
2. The arboricultural considerations - tree safety, good arboricultural practice (tree work) and aesthetics.

The client and their insurers are deemed to have accepted the limitation placed on the recommendations by the sources quoted in the attached report. Where sources are limited by time constraints or the client, this may lead to an incomplete quantification of the risk.

**Signed:**



February 2021.....

**For and on Behalf of Hayden's Arboricultural Consultants Limited**



## 8.0 References

British Standards Institute. (2010). *Recommendations for Tree Work BS 3998:2010* BSI, London.

British Standards Institute. (2012). *Trees in Relation to Design, Demolition and Construction – Recommendations BS5837:2012* BSI, London.

Ministry of Housing, Communities & Local Government. (2014). *Tree Preservation Orders and trees in conservation areas*. London: Ministry of Housing, Communities & Local Government.

Mattheck & Breloer, H. (1994). *Research for Amenity Trees No.4: The Body Language of Trees*, HMSO, London.

NHBC Standards (2007) *Chapter 4.2 'Building Near Trees'*. National House-Building Council.

NJUG 4 Guidelines for the planning, installation and maintenance of utility apparatus in proximity to trees. Issued 16 November 2007.

Forestry Commission (2007). *Tree Felling – Getting Permission*. Country Services Division, Forestry Commission, Edinburgh.

Patch, D. Holding, B. (2006) *Arboricultural Practice Note 12 (APN12), Through the Trees to Development*. Arboricultural Advisory and Information Service (AAIS).

Lonsdale, D. (1999). *Research for Amenity Trees No 7: Principles of Tree Hazard Assessment and Management*, HMSO, London.

DEFRA (1997). *The Hedgerow Regulations 1997 – A Guide to the Law and Good Practice*. Department of the Environment, Transport and the Regions, HMSO, London.

Schwabe, F.W.M.R. Engels, J. & Mattheck, C. (2000) *Fungal Strategies of Wood Decay in Trees*. Springer.

Strouts, R.G. & Winter, T.G. (1994). *Research for Amenity Trees No.2: Diagnosis of Ill-Health in Trees*. Department of the Environment, HMSO, London.

Weber, K., Mattheck, C. (2003). *Manual of Wood Decays*. The Arboricultural Association



## 9.0 Appendices

Appendix	<b>A</b>	Species List & Tree Problems
Appendix	<b>B</b>	Schedule of Trees
Appendix	<b>C</b>	Schedule of Works - Irrespective of Development
Appendix	<b>D</b>	Preliminary Schedule of Works to Allow Development
Appendix	<b>E</b>	Explanatory Notes
Appendix	<b>F</b>	Tree Preservation Order Enquiry/Response
Appendix	<b>G</b>	Advisory Information & Sample Specifications
		1. BS 5837:2012 Figure 1 - Flow Chart – Design and Construction & Tree Care
		2. European Protected Species and Woodland Operations Checklist (v.4)
		3. BS 5837:2012 Figure 2 - Default specification for protective barrier
		4. BS 5837:2012 Figure 3 - Examples of above-ground stabilising systems
Appendix	<b>H</b>	Drawing No 8100-D-AIA



## Appendix A - Species List & Tree Problems

### Species List:

Apple	<i>Malus sp</i>
Ash	<i>Fraxinus excelsior</i>
Atlas Cedar	<i>Cedrus atlantica</i>
Beech	<i>Fagus sylvatica</i>
Blackthorn	<i>Prunus spinosa</i>
Cherry Laurel	<i>Prunus laurocerasus</i>
Corkscrew Willow	<i>Salix babylonica var. pekinensis 'Tortuosa'</i>
Cypress	<i>Cupressus sp</i>
Elder	<i>Sambucus nigra</i>
English Oak	<i>Quercus robur</i>
English Yew	<i>Taxus baccata</i>
European Lime	<i>Tilia x europaea</i>
False Acacia	<i>Robinia pseudoacacia</i>
Field Maple	<i>Acer campestre</i>
Giant Sequoia	<i>Sequoiadendron giganteum</i>
Guelder Rose	<i>Viburnum opulus</i>
Hawthorn	<i>Crataegus monogyna</i>
Holly	<i>Ilex aquifolium</i>
Holm Oak	<i>Quercus ilex</i>
Hornbeam	<i>Carpinus betulus</i>
Horse Chestnut	<i>Aesculus hippocastanum</i>
Lawson Cypress	<i>Chamaecyparis lawsoniana</i>
Leyland Cypress	<i>X Cuprocyparis leylandii</i>
Mahonia	<i>Mahonia aquifolium</i>
Maidenhair tree	<i>Ginkgo biloba</i>
Norway Maple	<i>Acer platanoides</i>
Pear	<i>Pyrus sp</i>
Silver Birch	<i>Betula pendula</i>
Sycamore	<i>Acer pseudoplatanus</i>
Walnut	<i>Juglans regia</i>
White Poplar	<i>Populus alba</i>



## Tree Problems:

This gives a brief description of the problems identified in the attached Tree Survey.

<b>Name: Canker</b>	
<b>Symptoms/damage type and cause:</b>	This is a clearly defined patch of dead and sunken, or malformed bark which can be caused by either bacterial or fungal agents. Affected branches or stems can die due to being girdled by cankers.
<b>Consequence:</b>	Depending upon the affecting organism can cause death of limbs or in extreme cases death of whole tree.
<b>Control:</b>	In some instances, it may be possible to excise the infected area by tree surgery operations however this is dependent upon the distribution of infected tissues and outcomes may vary.
<b>Species affected:</b>	A wide range of tree species

<b>Name: Deadwood</b>	
<b>Symptoms/damage type and cause:</b>	This relates to dead branches in the crown of the tree. In the majority of cases, this is caused by the natural ageing process of the tree or shading due to its close proximity to neighbouring trees. However, in some situations, it may be related to fungal, bacterial or viral infection.
<b>Consequence:</b>	Depending upon the location and mass of dead wood removal of the affected tissue may be necessary to prevent harm to persons or property as the wood will become unstable as it decays and in some circumstances is likely to fall from the tree with little or no warning.
<b>Control:</b>	Detailed monitoring should be undertaken on those trees showing signs of excessive deadwood production to identify the underlying cause.
<b>Species affected:</b>	Most tree species.
<b>Images:</b>	



<b>Name:</b> <i>Hedera helix</i> (Ivy)	
<b>Symptoms/damage type and cause:</b>	Ivy may grow to varying degrees on all areas of a tree from the base to the upper crown. It is possible that in doing so it will out-compete the host tree for available light thereby suppressing the host.
<b>Consequence:</b>	This is generally only harmful to the tree on already unhealthy specimens which may be constricted by large ivy stems around the trunk or may have their top growth suppressed by a mass of flowering shoots in the crown. Ivy can also mask potentially dangerous faults on a tree.
<b>Control:</b>	Ivy should only be removed if absolutely necessary because it provides abundant cover to wildlife and then by severing twice close to the ground and removing a length of stem thereby causing the gradual dying away of the aerial parts of the plant providing extended benefit to wildlife whilst relieving the pressure on the tree.
<b>Species affected:</b>	Most trees can be affected.
<b>Images:</b>	



# **Appendix B**

Schedule of Trees



TreeNo	Species	DBH	Height		Visual	Crown Spread	Problems / Comments	BS Cat	Work Required (TS)	Priority (TS)	Work Required (AIA)	Priority (AIA)
			Min Dist	Crown Base								
			On site	RPA (m²)	Aspect	Aspect						
<b>A001</b>	Hornbeam, Norway Maple, Apple, Pear, Elder	350	7		Moderate	N4, E4, S4, W4	A small area bordering the site. Trees are quite dense here with some smaller trees missed off of the topo. DBH estimated due to stems being within hedge and Ivy. The Apple and Pear trees have typical deadwood caused by shading from adjacent foliage. No significant target below trees at present. Overhead cable is caught up in crowns.	C2	Prune to clear overhead cable by up to 1m.	3	Fell to ground level.	0
		4.2	0.5		M	Moderate						
<b>Yes</b>		55.4			10+ years	Hedge, Ivy						
<b>A002</b>	Corkscrew Willow, Elder, Apple, Pear, Field Maple	300	14		Moderate	N6, E6, S6, W6	Area cannot be accurately surveyed due to dense undergrowth and cover. Most notable item in this area is a Corkscrew Willow which has been marked with a point item.	C2	No work required	4	Install no dig surfacing.	0
		3.6	0		EM	High						
<b>Yes</b>		40.7			10+ years	Dense undergrowth						
<b>G001</b>	Hornbeam, Norway Maple	200	5.5		Moderate	N2.5, E2.5, S2.5, W2.5	Stems are within hedge preventing measurement of DBH. Norway Maple is suppressed by Hornbeam. Both trees form part of hedge boundary. Tree crowns interfere with overhead cable.	C2	Prune to clear overhead cable by up to 1m.	3		
		2.4	1.5		SM	Moderate						
<b>Yes</b>		18.1			20+ years	Hedge						
<b>G002</b>	Sycamore	300	10		Moderate	N3, E3, S3, W3	Two Sycamore, one semi-mature specimen and one smaller self-set specimen. Both trees are densely covered in Ivy on the main stem preventing full inspection. Trees are also located in the hedge. DBH estimated due to Ivy and hedge. Crowns appear healthy, although the smaller self-set specimen is a little suppressed.	B2	Remove all Ivy.	3		
		3.6	2.5		SM	Moderate						
<b>Yes</b>		40.7			20+ years	Ivy, Hedge						
<b>G003</b>	White Poplar	700	19		Moderate	N9.5, E9.5, S9.5, W9.5	A group of homogenous Poplar trees which are likely interdependent on one another for stability from wind. Main stems all emerge from within the hedge so DBH could not be taken. Main stems are clad in both live and severed Ivy. The crowns feature a typical amount of deadwood.	C2	Remove all deadwood.	2	Undertake linear root pruning and install no dig surfacing.	0
		8.4	3		M	High						
<b>Yes</b>		221.7			10+ years	Hedge						
<b>G004</b>	Leyland Cypress	350	19		Moderate	N4, E4, S4, W4	A short line of mature Leylandii. Trees are typically tall and negate a lot of light to neighbouring properties. Overall no significant issues at time of survey.	C2	No work required	4		
		4.2	0		M	High						
<b>Yes</b>		55.4			10+ years	Bare earth						

TreeNo	Species	DBH	Height		Visual	Crown Spread	Problems / Comments	BS Cat	Work Required (TS)	Priority (TS)	Work Required (AIA)	Priority (AIA)			
			Min Dist	Crown Base									Lowest Branch	Age	Water Demand
			RPA (m <sup>2</sup> )	Aspect									Aspect	SULE	Ground Cover
<b>G005</b>	Sycamore	1000	20		Moderate	N7.5, E7.5, S7.5, W7.5	A group of two mature Sycamore along the site boundary. Trees are of good form and condition with no significant issues at time of survey. Crowns are homogenous.	B2	No work required	4	Crown lift to 2.5m from ground level and install no dig surfacing.	0			
		12	1		M	Moderate									
<b>Yes</b>		452.4			20+ years	Grass									
<b>G006</b>	Silver Birch	170	8		Moderate	N2.5, E2.5, S2.5, W2.5	Group of three multi-stemmed Silver Birch. Overall no significant issues at time of survey.	B2	No work required	4	Undertake linear root pruning.	0			
		2.04	1		SM	Low									
<b>Yes</b>		13.1			20+ years	Grass									
<b>G007</b>	Field Maple	450	14		Moderate	N5, E5, S5, W5	A group of two off site Field Maples. Trees are both multi-stemmed in form Crowns are asymmetric due to adjacent trees on site. Overall no significant issues at time of survey.	B2	No work required	4	Install no dig surfacing.	0			
		5.4	0.5		EM	Moderate									
<b>No</b>		91.6			20+ years	Dense undergrowth									
<b>H001</b>	Beech	70	1		Moderate	N0.5, E0.5, S0.5, W0.5	Small formally kept Beech hedge. No significant issues at time of survey.	C2	No work required	4	Fell to ground level.	0			
		0.84	0		Y	Moderate									
<b>Yes</b>		2.2			10+ years	Bare earth, Gravel									
<b>H002</b>	Beech, Ash, Sycamore, Holly, Hornbeam, English Yew	100	5		Moderate	N1.5, E1.5, S1.5, W1.5	Mixed boundary hedgerow which is densely shrouded in Ivy. Bramble also encroaches in places.	C2	No work required	4					
		1.2	0		SM	Moderate									
<b>Yes</b>		4.5			10+ years	Ivy									
<b>H003</b>	Beech	70	1		Moderate	N0.5, E0.5, S0.5, W0.5	Small formally kept Beech hedge. No significant issues at time of survey.	C2	No work required	4					
		0.84	0		Y	Moderate									
<b>Yes</b>		2.2			10+ years	Bare earth, Gravel									
<b>H004</b>	Beech	70	1		Moderate	N0.5, E0.5, S0.5, W0.5	Small formally kept Beech hedge. No significant issues at time of survey.	C2	No work required	4					
		0.84	0		Y	Moderate									
<b>Yes</b>		2.2			10+ years	Bare earth, Gravel									
<b>H005</b>	Beech, Hawthorn, Field Maple	70	1.5		Moderate	N0.5, E0.5, S0.5, W0.5	Small formally kept Beech hedge. No significant issues at time of survey.	C2	No work required	4					
		0.84	0		Y	Moderate									
<b>Yes</b>		2.2			10+ years	Bare earth, Gravel									
<b>H006</b>	Hawthorn, Field Maple, Pear, Elder, Blackthorn, Cherry Laurel, English Yew, Ash, Guelder Rose, Mahonia	250	9		Moderate	N2, E2, S2, W2	A dense mixed boundary hedge. Overall no significant issues at time of survey.	C2	No work required	4	Install no dig surfacing.	0			
		3	0		M	High									
<b>Yes</b>		28.3			10+ years	Dense undergrowth									

TreeNo	Species	DBH	Height		Visual	Crown Spread	Problems / Comments	BS Cat	Work Required (TS)	Priority (TS)	Work Required (AIA)	Priority (AIA)			
			Min Dist	Crown Base									Lowest Branch	Age	Water Demand
			RPA (m²)	Aspect									Aspect	SULE	Ground Cover
H007	Beech	70	1		Moderate	N0.5, E0.5, S0.5, W0.5	Small formally kept Beech hedge. No significant issues at time of survey.	C2	No work required	4	Fell to ground level.	0			
		0.84	0		Y	Moderate									
Yes		2.2			10+ years	Bare earth, Gravel									
H008	Beech, Sycamore, Norway Maple, Elder, Ash	120	4		Moderate	N1, E1, S1, W1	A dense mixed boundary hedge. Overall no significant issues at time of survey.	C2	No work required	4					
		1.44	0		SM	Moderate									
Yes		6.5			10+ years	Dense undergrowth									
H009	English Yew	70	2		Low	N0.5, E0.5, S0.5, W0.5	Formally kept hedge for screening from properties to the rear of the site. No significant issues at time of survey.	C2	No work required	4					
		0.84	0		SM	Moderate									
Yes		2.2			10+ years	Grass									
H010	Japanese Skimmia	70	1.5		Moderate	N0.5, E0.5, S0.5, W0.5	Formally maintained hedge. No significant issues at time of survey.	C2	No work required	4	Fell to ground level.	0			
		0.84	0		SM	Moderate									
Yes		2.2			10+ years	Grass									
T001	Silver Birch	170	7		Moderate	N0.5, E1.5, S3.5, W3	Tree located in small grass area. Main stem is distorted as the tree has competed for light. Overall no significant issues at time of survey.	C2	No work required	4	Fell to ground level.	0			
		2.04	1.5		SM	Low									
Yes		13.1			10+ years	Grass									
T002	Silver Birch	150	7		Moderate	N0.5, E1.5, S3, W2	Tree located in small grass area. Main stem is distorted as the tree has competed for light. Overall no significant issues at time of survey.	C2	No work required	4	Fell to ground level.	0			
		1.8	1		SM	Low									
Yes		10.2			10+ years	Grass									
T003	Silver Birch	160	7.5		Moderate	N2, E3, S3, W2.5	Tree located in small grass area. Overall no significant issues at time of survey.	C2	No work required	4	Fell to ground level.	0			
		1.92	1		SM	Low									
Yes		11.6			10+ years	Grass									
T004	Norway Maple	150	6		Moderate	N2, E2, S2, W2	Tree located in shrub bed. No significant issues at time of survey.	C2	No work required	4	Install no dig surfacing.	0			
		1.8	2.5		SM	Moderate									
Yes		10.2			10+ years	Shrub bed									
T005	Sycamore	270	9.5		Moderate	N3, E3, S3, W3.5	Tree is densely covered in Ivy on the main stem preventing full inspection. Tree is also located in the hedge. DBH estimated due to Ivy and hedge. Crow appears healthy. No significant issues at time of survey.	B1	No work required	4					
		3.24	3		SM	Moderate									
Yes		33			20+ years	Ivy, Hedge									

TreeNo	Species	DBH	Height		Visual	Crown Spread	Problems / Comments	BS Cat	Work Required (TS)	Priority (TS)	Work Required (AIA)	Priority (AIA)			
			Min Dist	Crown Base									Lowest Branch	Age	Water Demand
			RPA (m <sup>2</sup> )	Aspect									Aspect	SULE	Ground Cover
T006	Horse Chestnut	570	11		High	N5, E4.5, S4.5, W5.5	Tree located in grass area next to car park. No significant issues at time of survey but crown is low over car park.	B1	Crown lift to 2.5m.	3					
		6.84	1.5		EM	Moderate									
Yes		147			20+ years	Grass									
T007	Ash	390	11		High	N3, E5, S5.5, W6	Tree located in grass area next to car park. No significant issues at time of survey.	B1	No work required	4					
		4.68	1.5		EM	Moderate									
Yes		68.8			20+ years	Grass									
T008	Horse Chestnut	490	11		High	N5.5, E4.5, S6, W6	Tree located in grass area next to car park. No significant issues at time of survey but crown is low over car park.	B1	Crown lift to 2.5m.	3					
		5.88	1.5		EM	Moderate									
Yes		108.6			20+ years	Grass									
T009	Ash	140	8		Moderate	N2.5, E2.5, S2.5, W2.5	Tree located in grass area next to car park. No significant issues at time of survey.	C1	No work required	4					
		1.68	1.5		SM	Moderate									
Yes		8.9			10+ years	Grass									
T010	Norway Maple	190	8		Moderate	N2.5, E2, S3, W3	Tree located in shrub bed. No significant issues at time of survey.	C2	No work required	4	Undertake linear root pruning.	0			
		2.28	4		SM	Moderate									
Yes		16.3			10+ years	Shrub bed									
T011	Norway Maple	160	7		Moderate	N2.5, E2.5, S2.5, W2.5	Tree located in shrub bed. No significant issues at time of survey.	C2	No work required	4					
		1.92	3		SM	Moderate									
Yes		11.6			10+ years	Shrub bed									
T012	Walnut	430	9		High	N5, E4.5, S4.5, W4.5	Some localised black stem bleeding on the west side of the main stem at approximately 1m. Crown is also not in a great condition with deadwood occurring in the apex.	B1	Remove all deadwood. Monitor annually for further deterioration.	3					
		5.16	2.5		EM	Moderate									
Yes		83.6			20+ years	Grass									
T013	Sycamore	260	8.5		High	N3, E2, S4, W3	Tree located in grass area next to car park. No significant issues at time of survey but some minor deadwood has occurred due to shading.	C1	Remove all deadwood.	3					
		3.12	3		SM	Moderate									
Yes		30.6			20+ years	Grass									
T014	Ash	480	11		High	N5.5, E6.5, S5, W4.5	Tree is twin-stemmed from 0.5m. Union is poor, being included and slightly cupped. Crown is quite extending and consideration should be given to install a non-invasive brace. Alternatively, consideration could be given to felling and replanting.	C1	Install non-invasive brace OR fell and replant.	2	Undertake linear root pruning.	0			
		5.76	2.5		EM	Moderate									
Yes		104.2			10+ years	Grass									

TreeNo	Species	DBH	Height		Visual	Crown Spread	Problems / Comments	BS Cat	Work Required (TS)	Priority (TS)	Work Required (AIA)	Priority (AIA)			
			Min Dist	Crown Base									Lowest Branch	Age	Water Demand
			RPA (m²)	Aspect									Aspect	SULE	Ground Cover
T015	Norway Maple	230	8		High	N3, E3, S3.5, W3	Tree located in grass verge next to road. No significant issues at time of survey.	C1	No work required	4					
		2.76	2.5		SM	Moderate									
Yes		23.9			10+ years	Grass									
T016	Norway Maple	200	7		High	N3, E3, S3.5, W3.5	Tree located in grass verge next to road. No significant issues at time of survey.	C1	No work required	4					
		2.4	2		SM	Moderate									
Yes		18.1			10+ years	Grass									
T017	Norway Maple	260	8		High	N3.5, E4.5, S4.5, W3.5	Tree located in grass verge next to road. No significant issues at time of survey.	C1	No work required	4					
		3.12	2		SM	Moderate									
Yes		30.6			10+ years	Grass									
T018	Norway Maple	190	7.5		High	N3.5, E3, S3.5, W3.5	Tree located in grass verge next to road. Tree has previously lost a central leader. Overall no significant issues at time of survey.	C1	No work required	4					
		2.28	2		SM	Moderate									
Yes		16.3			10+ years	Grass									
T019	Norway Maple	410	10		High	N3, E5.5, S4.5, W4.5	Tree located in grass verge next to road. No significant issues at time of survey.	B1	No work required	4					
		4.92	1.5		EM	Moderate									
Yes		76			20+ years	Grass									
T020	European Lime	420	10		High	N2, E3.5, S1, W3.5	Multi-stemmed specimen on grass verge next to road. Main unions are tight but included. Crown is suppressed and asymmetric due to adjacent trees.	C2	No work required	4					
		5.04	2		EM	Moderate									
Yes		79.8			10+ years	Grass									
T021	Norway Maple	400	8.5		High	N5, E5.5, S3, W5.5	Tree is in a very poor condition and is almost dead. Tree has succumbed to Bleeding Canker.	U	Fell and replant.	2					
		4.8	2		EM	Moderate									
Yes		72.4			<10 years	Grass									
T022	European Lime	260	9		High	N2.5, E4, S3, W4	Tree located in grass verge next to road. No significant issues at time of survey.	C1	No work required	4					
		3.12	2		SM	Moderate									
Yes		30.6			10+ years	Grass									
T023	Norway Maple	340	9		High	N3.5, E4, S3, W4	Tree located in grass verge next to road. No significant issues at time of survey.	B1	No work required	4	Fell to ground level.	0			
		4.08	2		EM	Moderate									
Yes		52.3			20+ years	Grass									

TreeNo	Species	DBH	Height		Visual	Crown Spread	Problems / Comments	BS Cat	Work Required (TS)	Priority (TS)	Work Required (AIA)	Priority (AIA)			
			Min Dist	Crown Base									Lowest Branch	Age	Water Demand
			RPA (m²)	Aspect									Aspect	SULE	Ground Cover
T024	European Lime	210	7		Low	N4, E3.5, S3, W4	Tree located in formally kept hedge. No significant issues at time of survey	C1	No work required	4	Undertake linear root pruning.	0			
		2.52	2		SM	Moderate									
Yes		20			10+ years	Grass									
T025	European Lime	180	7		Moderate	N2.5, E2.5, S2.5, W2.5	Tree located in formally kept hedge. No significant issues at time of survey	C1	No work required	4					
		2.16	2		SM	Moderate									
Yes		14.7			10+ years	Grass									
T026	European Lime	80	5		Moderate	N1.5, E0.5, S1.5, W0.5	No significant issues at time of survey	C1	No work required	4					
		0.96	1.5		Y	Moderate									
Yes		2.9			10+ years	Grass									
T027	European Lime	220	10		Moderate	N2.5, E3.5, S3, W3.5	No significant issues at time of survey	B1	No work required	4	Fell to ground level.	0			
		2.64	2		SM	Moderate									
Yes		21.9			20+ years	Grass									
T028	European Lime	210	10		Moderate	N3, E3.5, S3, W3	No significant issues at time of survey	B1	No work required	4	Tree to be moved with tree spade and will be replaced in result of failure.	0			
		2.52	2		SM	Moderate									
Yes		20			20+ years	Grass									
T029	European Lime	200	9.5		Moderate	N3, E3.5, S3, W3	No significant issues at time of survey	B1	No work required	4	Tree to be moved with tree spade and will be replaced in result of failure.	0			
		2.4	2		SM	Moderate									
Yes		18.1			20+ years	Grass									
T030	European Lime	180	7		Moderate	N3, E3, S2.5, W3	No significant issues at time of survey	B1	No work required	4					
		2.16	2		SM	Moderate									
Yes		14.7			20+ years	Grass									
T031	European Lime	200	9.5		Moderate	N3, E4, S3, W3	No significant issues at time of survey	B1	No work required	4					
		2.4	2		SM	Moderate									
Yes		18.1			20+ years	Grass									
T032	European Lime	140	6.5		Moderate	N2.5, E3, S2, W2.5	No significant issues at time of survey	C1	No work required	4					
		1.68	2		SM	Moderate									
Yes		8.9			10+ years	Grass									

TreeNo	Species	DBH	Height		Visual	Crown Spread	Problems / Comments	BS Cat	Work Required (TS)	Priority (TS)	Work Required (AIA)	Priority (AIA)			
			Min Dist	Crown Base									Lowest Branch	Age	Water Demand
			RPA (m²)	Aspect									Aspect	SULE	Ground Cover
T033	European Lime	180	7.5		Moderate	N3, E3.5, S3, W3	No significant issues at time of survey	B1	No work required	4	Install no dig surfacing.	0			
		2.16	2		SM	Moderate									
Yes		14.7			20+ years	Grass									
T034	European Lime	150	6.5		Moderate	N2.5, E2.5, S2.5, W3	No significant issues at time of survey	C1	No work required	4					
		1.8	2		SM	Moderate									
Yes		10.2			10+ years	Grass									
T035	Giant Redwood	300	9		Low	N2.5, E2.5, S2.5, W2.5	No significant issues at time of survey	B1	No work required	4	Undertake linear root pruning and install no dig surfacing.	0			
		3.6	0		SM	Moderate									
Yes		40.7			20+ years	Grass									
T036	Ash	300	14		Moderate	N4, E2, S4, W4.5	Tree located within dense hedge and Ivy. Ivy and hedge prevent full inspection and taking of DBH. Crown is suppressed and asymmetric due to adjacent Poplar.	C2	No work required	4					
		3.6	1.5		EM	Moderate									
Yes		40.7			10+ years	Dense undergrowth									
T037	Field Maple	220	13		Moderate	N3, E4, S3, W2.5	Tree located within dense hedge and Ivy. Ivy and hedge prevent full inspection and taking of DBH. Crown is suppressed and asymmetric due to adjacent Leylandii.	B2	No work required	4					
		2.64	2.5		EM	Moderate									
Yes		21.9			20+ years	Dense undergrowth									
T038	Sycamore	200	10		Moderate	N2, E0.5, S4, W3	A very suppressed specimen of Sycamore of limited form.	C2	No work required	4					
		2.4	1.5		SM	Moderate									
Yes		18.1			10+ years	Bare earth, Dense undergrowth									
T039	Purple Leaved Cherry Plum	300	7		Moderate	N3, E3, S3, W3	Typical multi-stemmed specimen with a tight spindly form. Overall no significant issues at time of survey.	C1	No work required	4					
		3.6	1		EM	Moderate									
Yes		40.7			10+ years	Grass									
T040	Lawson Cypress	100	2.5		Moderate	N1, E1, S1, W1	Young bushy specimen. No significant issues at time of survey.	C2	No work required	4					
		1.2	0		Y	Moderate									
Yes		4.5			10+ years	Grass									
T041	Lawson Cypress	100	2.5		Moderate	N1, E1, S1, W1	Young bushy specimen. No significant issues at time of survey.	C2	No work required	4					
		1.2	0		Y	Moderate									
Yes		4.5			10+ years	Grass									

TreeNo	Species	DBH	Height		Visual	Crown Spread	Problems / Comments	BS Cat	Work Required (TS)	Priority (TS)	Work Required (AIA)	Priority (AIA)			
			Min Dist	Crown Base									Lowest Branch	Age	Water Demand
			RPA (m²)	Aspect									Aspect	SULE	Ground Cover
T042	Apple Species	250	6		Moderate	N3, E3, S2.5, W3	Apple tree in fair to poor condition. Crown has dieback and deadwood within. Tree located in unused part of the site.	C2	No work required	4					
		3	1		M	Moderate									
Yes		28.3			10+ years	Grass									
T043	Atlas Cedar	250	8.5		Moderate	N3.5, E3, S2.5, W2.5	No significant issues at time of survey	B1	No work required	4	Tree to be moved with tree spade and will be replaced in result of failure.	0			
		3	1		SM	Moderate									
Yes		28.3			20+ years	Grass									
T044	European Lime	250	8		Low	N4, E4, S3, W3	No significant issues at time of survey	B2	No work required	4	Undertake linear root pruning and install no dig surfacing.	0			
		3	2.5		SM	Moderate									
Yes		28.3			20+ years	Grass									
T045	European Lime	220	7.5		Low	N2.5, E3, S3, W3	No significant issues at time of survey	B2	No work required	4	Install no dig surfacing.	0			
		2.64	2.5		SM	Moderate									
Yes		21.9			20+ years	Grass									
T046	Atlas Cedar	250	9.5		Moderate	N3, E3.5, S4, W3.5	No significant issues at time of survey	B1	No work required	4	Crown lift to 2.5m from ground level and install no dig surfacing.	0			
		3	1		SM	Moderate									
Yes		28.3			20+ years	Grass									
T047	European Lime	210	7.5		Moderate	N3, E3, S3.5, W3.5	No significant issues at time of survey	B2	No work required	4					
		2.52	2.5		SM	Moderate									
Yes		20			20+ years	Grass									
T048	European Lime	160	6		Moderate	N3.5, E2.5, S2, W3	No significant issues at time of survey	C1	No work required	4					
		1.92	2.5		SM	Moderate									
Yes		11.6			10+ years	Grass									
T049	European Lime	190	8		Moderate	N3, E2.5, S2.5, W2.5	No significant issues at time of survey	B2	No work required	4	Tree to be moved with tree spade and will be replaced in result of failure.	0			
		2.28	2.5		SM	Moderate									
Yes		16.3			20+ years	Grass									
T050	European Lime	150	6		Moderate	N2.5, E2, S2, W2	No significant issues at time of survey	C1	No work required	4	Fell to ground level.	0			
		1.8	2.5		SM	Moderate									
Yes		10.2			10+ years	Grass									



TreeNo	Species	DBH	Height		Visual	Crown Spread	Problems / Comments	BS Cat	Work Required (TS)	Priority (TS)	Work Required (AIA)	Priority (AIA)			
			Min Dist	Crown Base									Lowest Branch	Age	Water Demand
			RPA (m <sup>2</sup> )	Aspect									Aspect	SULE	Ground Cover
T051	European Lime	200	7.5		Moderate	N2.5, E3, S2.5, W3.5	No significant issues at time of survey	B2	No work required	4	Tree to be moved with tree spade and will be replaced in result of failure.	0			
		2.4	2.5		SM	Moderate									
Yes		18.1			20+ years	Grass									
T052	European Lime	230	8.5		Moderate	N3.5, E3.5, S3, W3.5	No significant issues at time of survey	B2	No work required	4	Tree to be moved with tree spade and will be replaced in result of failure.	0			
		2.76	2.5		SM	Moderate									
Yes		23.9			20+ years	Grass									
T053	European Lime	200	7.5		Moderate	N2.5, E3.5, S3, W3.5	No significant issues at time of survey	B2	No work required	4	Tree to be moved with tree spade and will be replaced in result of failure.	0			
		2.4	2.5		SM	Moderate									
Yes		18.1			20+ years	Grass									
T054	European Lime	260	10		Moderate	N3.5, E3.5, S2.5, W3.5	No significant issues at time of survey	B2	No work required	4	Tree to be moved with tree spade and will be replaced in result of failure.	0			
		3.12	2.5		SM	Moderate									
Yes		30.6			20+ years	Grass									
T055	False Acacia	490	14		Moderate	N5, E5, S5, W5	Twin-stemmed specimen from base with a tight but sufficient union. Crown is well formed with a typical amount of deadwood. Overall no significant issues at time of survey.	B2	No work required	4	Fell to ground level.	0			
		5.88	2.5		M	Moderate									
Yes		108.6			20+ years	Grass									
T056	Cypress Species	110	8		Moderate	N0.5, E0.5, S0.5, W0.5	Tree situated close to wall of building. No significant issues at time of survey	C1	No work required	4	Fell to ground level.	0			
		1.32	0		SM	Moderate									
Yes		5.5			10+ years	Gravel									
T057	Cypress Species	110	8		Moderate	N0.5, E0.5, S0.5, W0.5	Tree situated close to wall of building. No significant issues at time of survey	C1	No work required	4	Fell to ground level.	0			
		1.32	0		SM	Moderate									
Yes		5.5			10+ years	Gravel									
T058	Cypress Species	110	8		Moderate	N0.5, E0.5, S0.5, W0.5	Tree situated close to wall of building. No significant issues at time of survey	C1	No work required	4	Fell to ground level.	0			
		1.32	0		SM	Moderate									
Yes		5.5			10+ years	Gravel									
T059	Cypress Species	110	8		Moderate	N0.5, E0.5, S0.5, W0.5	Tree situated close to wall of building. No significant issues at time of survey	C1	No work required	4	Fell to ground level.	0			
		1.32	0		SM	Moderate									
Yes		5.5			10+ years	Gravel									

TreeNo	Species	DBH	Height		Visual	Crown Spread	Problems / Comments	BS Cat	Work Required (TS)	Priority (TS)	Work Required (AIA)	Priority (AIA)			
			Min Dist	Crown Base									Lowest Branch	Age	Water Demand
			RPA (m²)	Aspect									Aspect	SULE	Ground Cover
T060	English Oak	530	12		Moderate	N9.5, E9.5, S7.5, W7.5	A low but wide spreading specimen. Tree is in good form but slightly overshadowed by the adjacent Cedar. Major and minor deadwood within crown.	B1	Remove all deadwood.	2	Install no dig surfacing.	0			
		6.36	2.5		EM	High									
Yes		127.1			40+ years	Grass									
T061	Atlas Cedar	810	12		Moderate	N6.5, E7.5, S6.5, W8	A maturing Cedar. Tree has possibly been topped in the past as there is no clear dominant leader. Tree therefore has a typical outward growing form rather than upwards. Overall no significant issues at time of survey.	B1	No work required	4	Install no dig surfacing.	0			
		9.72	1.5		EM	Moderate									
Yes		296.8			20+ years	Grass									
T062	Walnut	200	9		Moderate	N1.5, E4, S4.5, W4	Tree has formed beneath the adjacent Cedar. This has caused the tree to grow in a distorted and asymmetric form. No significant issues at time of survey.	C2	No work required	4					
		2.4	1.5		SM	Moderate									
Yes		18.1			10+ years	Ivy									
T063	Field Maple	350	12		Moderate	N2.5, E2.5, S3, W4.5	Tree located within dense shrub/hedge row. Very upright form as it competes for light. No significant issues at time of survey.	B2	No work required	4					
		4.2	3		SM	Moderate									
Yes		55.4			20+ years	Dense undergrowth									
T064	Norway Maple	300	12		Moderate	N2.5, E2.5, S3, W4	Tree located within dense shrub/hedge row. Very upright form as it competes for light. No significant issues at time of survey.	C2	No work required	4					
		3.6	3		SM	Moderate									
Yes		40.7			10+ years	Dense undergrowth									
T065	Walnut	240	12		Moderate	N6.5, E1, S0.5, W5	Tree has formed beneath the adjacent trees. This has caused the tree to grow in a distorted and asymmetric form. No significant issues at time of survey.	C2	No work required	4					
		2.88	1		SM	Moderate									
Yes		26.1			10+ years	Ivy, Dense undergrowth									
T066	English Yew	400	10		Moderate	N4, E4, S4, W3	Multi-stemmed specimen in the understorey. No significant issues at time of survey.	B2	No work required	4					
		4.8	2		EM	Moderate									
Yes		72.4			20+ years	Ivy, Dense undergrowth									
T067	Maidenhair Tree	490	15		Moderate	N4, E5, S3.5, W4.5	Main stem has some minor bark damage on lower main stem. Occlusion is good. Main stem has a slight lean to the east. Some deadwood within crown due to shading from adjacent trees. Overall no significant issues at time of survey.	B2	No work required	4	Install no dig surfacing.	0			
		5.88	2.5		M	Moderate									
Yes		108.6			20+ years	Grass									
T068	False Acacia	390	15		Moderate	N3.5, E3, S4.5, W4.5	Tree has formed beneath the adjacent trees. This has caused the tree to grow in a distorted and asymmetric form. No significant issues at time of survey.	B2	No work required	4					
		4.68	9		M	Moderate									
Yes		68.8			20+ years	Dense undergrowth, Ivy									

TreeNo	Species	DBH	Height		Visual	Crown Spread	Problems / Comments	BS Cat	Work Required (TS)	Priority (TS)	Work Required (AIA)	Priority (AIA)	
			Min Dist	Crown Base									Lowest Branch
			On site	RPA (m <sup>2</sup> )	Aspect	Aspect							SULE
<b>T069</b>	English Yew	450	12		Moderate	N4.5, E4, S4.5, W4	Tree is in a poor condition with a virtually dead crown. No signs as to the cause.	U	Fell and replant.	3			
		5.4	2		M	Moderate							
<b>Yes</b>		91.6			<10 years	Ivy, Dense undergrowth							
<b>T070</b>	Giant Redwood	2040	25		High	N6.5, E5.5, S7, W6.5	Large mature specimen in good form and condition. Some form of bracing is present on the main stem high in the crown. It cannot be identified as to what it is for from the ground.	A3	Undertake climbing inspection to identify bracing.	3	Undertake linear root pruning. Install no dig surfacing.	0	
		15	0		M	Moderate							
<b>Yes</b>		706.9			40+ years	Bare earth							
<b>T071</b>	Holm Oak	880	11		Moderate	N3, E5, S4.5, W3.5	A twin-stemmed specimen from base. Tree has been pollarded in the past to manage size. Reformed crown is good. Overall no significant issues at time of survey.	A3	No work required	4	Fell to ground level.	0	
		10.56	1.5		M	High							
<b>Yes</b>		350.3			40+ years	Grass							

## **Appendix C**

Schedule of Works - Irrespective of Development

# SCHEDULE OF WORK IRRESPECTIVE OF DEVELOPMENT

Hotel Felix, Whitehouse Lane, Huntingdon Road, Girton, Cambridgeshire

Surveyed By: Steve Holyland

Surveyed: 15/04/2020

Managed By: Steve Holyland

Tree No.	Species	Work required	Priority
<b>G003</b>	White Poplar	Remove all deadwood.	<b>2</b>
<b>T014</b>	Ash	Install non-invasive brace OR fell and replant.	<b>2</b>
<b>T021</b>	Norway Maple	Fell and replant.	<b>2</b>
<b>T060</b>	English Oak	Remove all deadwood.	<b>2</b>
<b>A001</b>	Hornbeam, Norway Maple, Apple, Pear, Elder	Prune to clear overhead cable by up to 1m.	<b>3</b>
<b>G001</b>	Hornbeam, Norway Maple	Prune to clear overhead cable by up to 1m.	<b>3</b>
<b>G002</b>	Sycamore	Remove all Ivy.	<b>3</b>
<b>T006</b>	Horse Chestnut	Crown lift to 2.5m.	<b>3</b>
<b>T008</b>	Horse Chestnut	Crown lift to 2.5m.	<b>3</b>
<b>T012</b>	Walnut	Remove all deadwood.	<b>3</b>
<b>T013</b>	Sycamore	Remove all deadwood.	<b>3</b>
<b>T069</b>	English Yew	Fell and replant.	<b>3</b>
<b>T070</b>	Giant Redwood	Undertake climbing inspection to identify bracing.	<b>3</b>

## Schedule of Enhanced Monitoring

Hotel Felix, Whitehouse Lane, Huntingdon Road, Girton, Cambridgeshire

Surveyed By: Steve Holyland

Surveyed: 15/04/2020

Managed By: Steve Holyland

Tree No.	Species	Work required	Priority
<b>T012</b>	Walnut	Monitor annually for further deterioration.	<b>3</b>

---

## **Appendix D**

Preliminary Schedule of Works to Allow Development

## SCHEDULE OF WORKS (AIA)

Hotel Felix, Whitehouse Lane, Huntingdon Road, Girton, Cambridgeshire

Surveyed By: Steve Holyland

Surveyed: 15/04/2020

Managed By: Steve Holyland

Tree No.	Species	Work required	Priority
A001	Hornbeam, Norway Maple, Apple, Pear, Elder	Fell to ground level.	0
A002	Corkscrew Willow, Elder, Apple, Pear, Field Maple	Install no dig surfacing.	0
G003	White Poplar	Undertake linear root pruning and install no dig surfacing.	0
G005	Sycamore	Crown lift to 2.5m from ground level and install no dig surfacing.	0
G006	Silver Birch	Undertake linear root pruning.	0
G007	Field Maple	Install no dig surfacing.	0
H001	Beech	Fell to ground level.	0
H006	Hawthorn, Field Maple, Pear, Elder, Blackthorn, Cherry Laurel, English Yew, Ash, Guelder Rose, Mahonia	Install no dig surfacing.	0
H007	Beech	Fell to ground level.	0
H010	Japanese Skimmia	Fell to ground level.	0
T001	Silver Birch	Fell to ground level.	0
T002	Silver Birch	Fell to ground level.	0
T003	Silver Birch	Fell to ground level.	0
T004	Norway Maple	Install no dig surfacing.	0
T010	Norway Maple	Undertake linear root pruning.	0
T014	Ash	Undertake linear root pruning.	0
T023	Norway Maple	Fell to ground level.	0
T024	European Lime	Undertake linear root pruning.	0
T027	European Lime	Fell to ground level.	0
T028	European Lime	Tree to be moved with tree spade and will be replaced in result of failure.	0
T029	European Lime	Tree to be moved with tree spade and will be replaced in result of failure.	0
T033	European Lime	Install no dig surfacing.	0
T035	Giant Redwood	Undertake linear root pruning and install no dig surfacing.	0
T043	Atlas Cedar	Tree to be moved with tree spade and will be replaced in result of failure.	0
T044	European Lime	Undertake linear root pruning and install no dig surfacing.	0
T045	European Lime	Install no dig surfacing.	0
T046	Atlas Cedar	Crown lift to 2.5m from ground level and install no dig surfacing.	0
T049	European Lime	Tree to be moved with tree spade and will be replaced in result of failure.	0



Tree No.	Species	Work required	Priority
<b>T050</b>	European Lime	Fell to ground level.	<b>0</b>
<b>T051</b>	European Lime	Tree to be moved with tree spade and will be replaced in result of failure.	<b>0</b>
<b>T052</b>	European Lime	Tree to be moved with tree spade and will be replaced in result of failure.	<b>0</b>
<b>T053</b>	European Lime	Tree to be moved with tree spade and will be replaced in result of failure.	<b>0</b>
<b>T054</b>	European Lime	Tree to be moved with tree spade and will be replaced in result of failure.	<b>0</b>
<b>T055</b>	False Acacia	Fell to ground level.	<b>0</b>
<b>T056</b>	Cypress Species	Fell to ground level.	<b>0</b>
<b>T057</b>	Cypress Species	Fell to ground level.	<b>0</b>
<b>T058</b>	Cypress Species	Fell to ground level.	<b>0</b>
<b>T059</b>	Cypress Species	Fell to ground level.	<b>0</b>
<b>T060</b>	English Oak	Install no dig surfacing.	<b>0</b>
<b>T061</b>	Atlas Cedar	Install no dig surfacing.	<b>0</b>
<b>T067</b>	Maidenhair Tree	Install no dig surfacing.	<b>0</b>
<b>T070</b>	Giant Redwood	Undertake linear root pruning. Install no dig surfacing.	<b>0</b>
<b>T071</b>	Holm Oak	Fell to ground level.	<b>0</b>

---

## **Appendix E**

Explanatory Notes

# Explanatory Notes



## Categories

Below is an explanation of the categories used in the attached Tree Survey.

**No** Identifies the tree on the drawing.

**Species** Common names are given to aid understanding for the wider audience.

**BS 5837 Main Category** Using this assessment (BS 5837:2012, Table 1), trees can be divided into one of the following simplified categories, and are differentiated by cross-hatching and by colour on the attached drawing:

**Category A** - Those of high quality with an estimated remaining life expectancy of at least 40 years;

**Category B** - Those of moderate quality with an estimated remaining life expectancy of at least 20 years;

**Category C** - Those of low quality with an estimated remaining life expectancy of at least 10 years, or young trees with a stem diameter below 150 mm;

**Category U** - Those trees in such condition that they cannot realistically be retained as living trees in the context of the current land use for longer than 10 years.

**BS 5837 Sub Category** Table 1 of BS 5837:2012 also requires a sub category to be applied to the A, B, C, and U assessments. This allows for a further understanding of the determining classification as follows:

**Sub Category 1** - Mainly arboricultural qualities;

**Sub Category 2** - Mainly landscape qualities;

**Sub Category 3** - Mainly cultural values, including conservation .

Please note that a specimen or landscape feature may fulfil the requirements of more than one Sub Category.

**DBH (mm)** Diameter of main stem in millimetres at 1.5 metres from ground level. Where the tree is a multi-stem, the diameter is calculated in accordance with item 4.6.1 of BS 5837:2012.

**Age** Recorded as one of seven categories:

**Y** Young. Recently planted or establishing tree that could be transplanted without specialist equipment, i.e. less than 150 mm DBH.

**S/M** Semi-mature. An established tree, but one which has not reached its prospective ultimate height.

**E/M** Early-mature. A tree that is reaching its ultimate potential height, whose growth rate is slowing down but if healthy, will still increase in stem diameter and crown spread.

**M** Mature. A mature specimen with limited potential for any significant increase in size, even if healthy.

**O/M** Over-mature. A senescent or moribund specimen with a limited safe useful life expectancy. Possibly also containing sufficient structural defects with attendant safety and/or duty of care implications.



## D Dead.

<b>Height</b>	Recorded in metres, measured from the base of the tree.
<b>Crown Base</b>	Recorded in metres, the distance from ground and aspect of the lowest branch material.
<b>Lowest Branch</b>	Recorded in metres, the distance from ground and aspect of the emergence point of the lowest significant branch.
<b>Life Expectancy</b>	Relates to the prospective life expectancy of the tree and is given as 4 categories:  1 = 40 years+; 2 = 20 years+; 3 = 10 years+; 4 = less than 10 years.
<b>Crown Spread</b>	Indicates the radius of the crown from the base of the tree in each of the northern, eastern, southern and western aspects.
<b>Minimum Distance</b>	This is a distance equal to 12 times the diameter of the tree measured at 1.5 metres above ground level for single stemmed trees and 12 times the average diameter of the tree measured at 1.5 metres above ground level tree for multi stemmed specimens. (BS 5837:2012, section 4.6).
<b>RPA</b>	This is the Root Protection Area, measured in square metres and defined in BS5837:2012 as “a layout design tool indicating the minimum area around a tree deemed to contain sufficient roots and rooting volume to maintain the tree’s viability, and where the protection of the roots and soil structure is treated as a priority”. The RPA is shown on the drawing.. Ideally this is an area around the tree that must be kept clear of construction, level changes of construction operations. Some methods of construction can be carried out within the RPA of a retained tree but only if approved by the Local Planning Authority’s tree officer.
<b>Water Demand</b>	This gives the water demand of the species of tree when mature, as given in the NHBC Standards Chapter 4.2 “Building Near Trees”.
<b>Visual Amenity</b>	Concerns the planning and landscape contribution to the development site made by the tree, hedge or tree group, in terms of its amenity value and prominence on the skyline along with functional criteria such as the screening value, shelter provision and wildlife significance. The usual definitions are as follows:  Low            An inconsequential landscape feature.  Moderate      Of some note within the immediate vicinity, but not significant in the wider context.  High            Item of high visual importance.
<b>Problems/ Comments</b>	May include general comments about growth characteristic, how it is affected by other trees and any previous surgery work; also, specific problems such as deadwood, pests, diseases, broken limbs, etc.
<b>Work Required (TS)</b>	Identifies the necessary tree work to mitigate anticipated problems and deal with existing problems identified in the “Problems/comments” category.



**Work Required (AIA)**

Identifies the tree work specifically necessary to allow a proposed development to proceed.

**Priority**

This gives a priority rating to each tree allowing the client to prioritise necessary tree works identified within the Tree Survey.

- 1 Urgent – works required immediately;
- 2 Works required within 6 months;
- 3 Works required within 1 year;
- 4 Re-inspect in 12 months,
- 0 Remedial works as part of implementation of planning consent.



## BS 5837:2012 Terms and Definitions

<b>Access Facilitation Pruning</b>	One-off tree pruning operation, the nature and effects of which are without significant adverse impact on tree physiology or amenity value, which is directly necessary to provide access for operations on site.
<b>Arboricultural Method Statement</b>	Methodology for the implementation of any aspect of development that is within the root protection area, or has the potential to result in loss of or damage to a tree to be retained.
<b>Arboriculturist</b>	Person who has, through relevant education, training and experience, gained expertise in the field of trees in relation to construction.
<b>Competent Person</b>	Person who has training and experience relevant to the matter being addressed and an understanding of the requirements of the particular task being approached. <i>NOTE - a competent person is expected to be able to advise on the best means by which the recommendations of this British Standard may be implemented.</i>
<b>Construction</b>	Site-based operations with the potential to affect existing trees.
<b>Construction Exclusion Zone</b>	Area based on the root protection area from which access is prohibited for the duration of a project.
<b>Root Protection Area (RPA)</b>	Layout design tool indicating the minimum area around a tree deemed to contain sufficient roots and rooting volume to maintain the tree's viability, and where the protection of the roots and soil structure is treated as a priority.
<b>Service</b>	Any above or below ground structure or apparatus required for utility provision. <b>NOTE</b> - examples include drainage, gas supplies, ground source heat pumps, CCTV and satellite communications.
<b>Stem</b>	Principal above ground structural component(s) of a tree that supports its branches.
<b>Structure</b>	Manufactured object, such as a building, carriageway, path, wall, service run, and built or excavated earthwork.
<b>Tree Protection Plan</b>	Scale drawing, informed by descriptive text where necessary, based upon the finalized proposals, showing trees for retention and illustrating the tree and landscape protection measures.
<b>Veteran Tree</b>	Tree that, by recognized criteria, shows features of biological, cultural or aesthetic value that are characteristic of, but not exclusive to, individuals surviving beyond the typical age range for the species concerned. <b>NOTE</b> - these characteristics might typically include a large girth, signs of crown retrenchment and hollowing of the stem.



## **Appendix F**

Tree Preservation Order Enquiry/Response

Tree Preservation Orders

- Tree Preservation Order
- Region
- Region
- ▶ **Listed Buildings**
- ▼ **Conservation Areas**
- Conservation Area
- ▶ **Development Frameworks**
- ▶ **Parishes**
- ▶ **Green Belt**

**Search by Planning Reference**

**Find**

**Search for an Address**

**Find**

**Find**

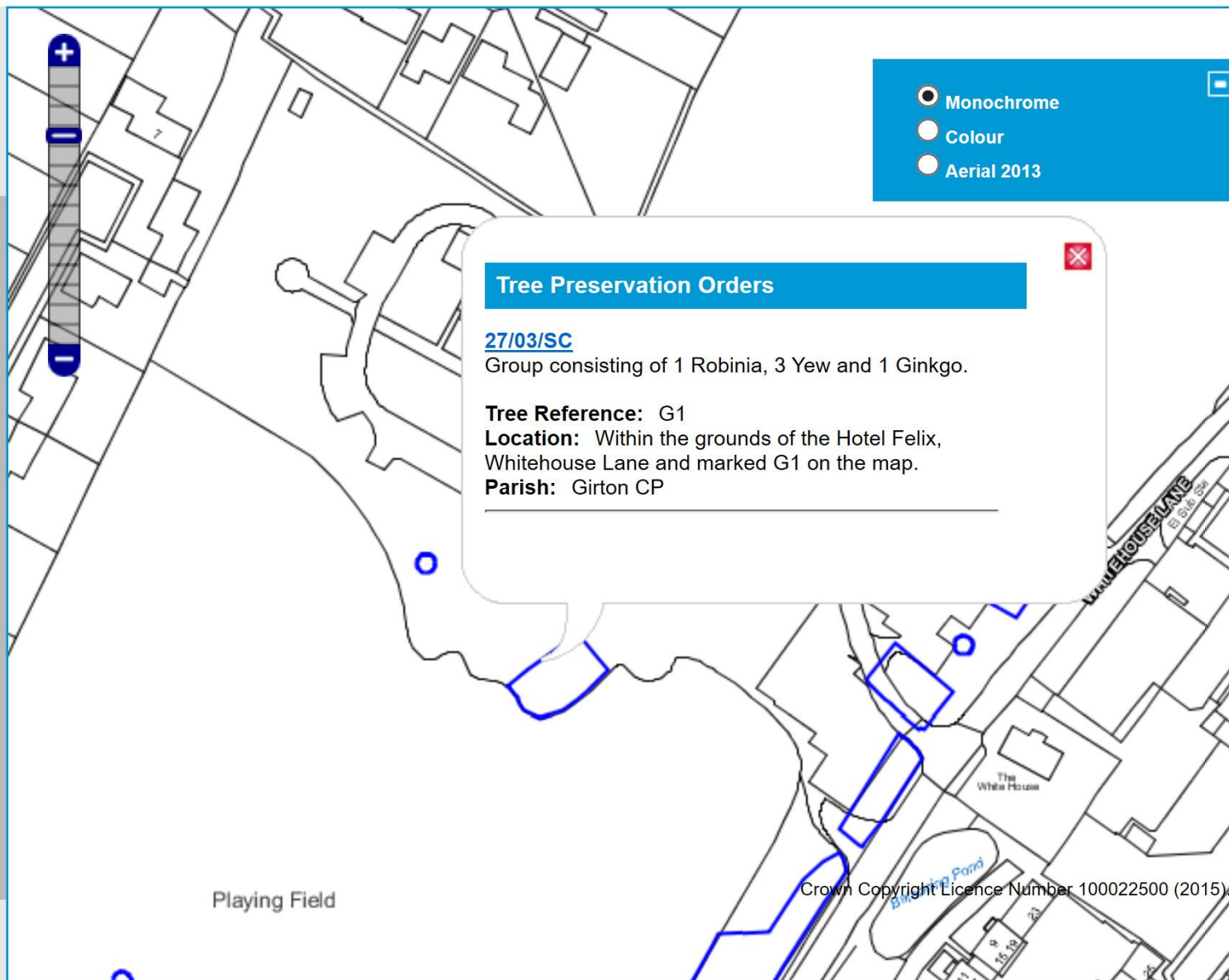

- Monochrome
- Colour
- Aerial 2013



Tree Preservation Orders

- Tree Preservation Order
  - Region
  - Region
- ▶ Listed Buildings
- ▼ Conservation Areas 
  - Conservation Area
- ▶ Development Frameworks
- ▶ Parishes
- ▶ Green Belt

Search by Planning Reference

Find

Search for an Address

Find

Find

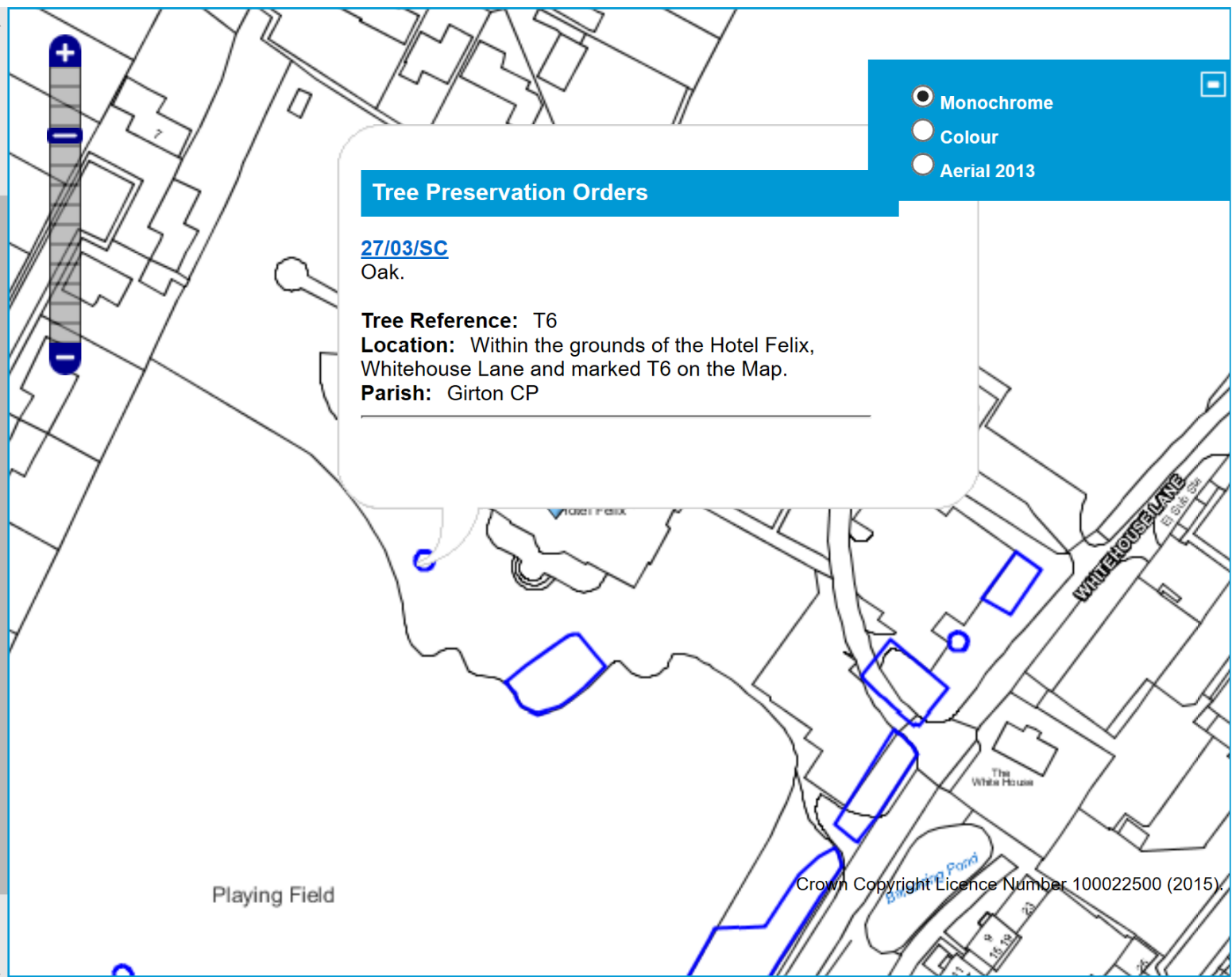

Tree Preservation Orders

- Tree Preservation Order
  - Region
  - Region
- Listed Buildings
- Conservation Areas
  - Conservation Area
- Development Frameworks
- Parishes
- Green Belt

Search by Planning Reference

Find

Search for an Address

Find

Find

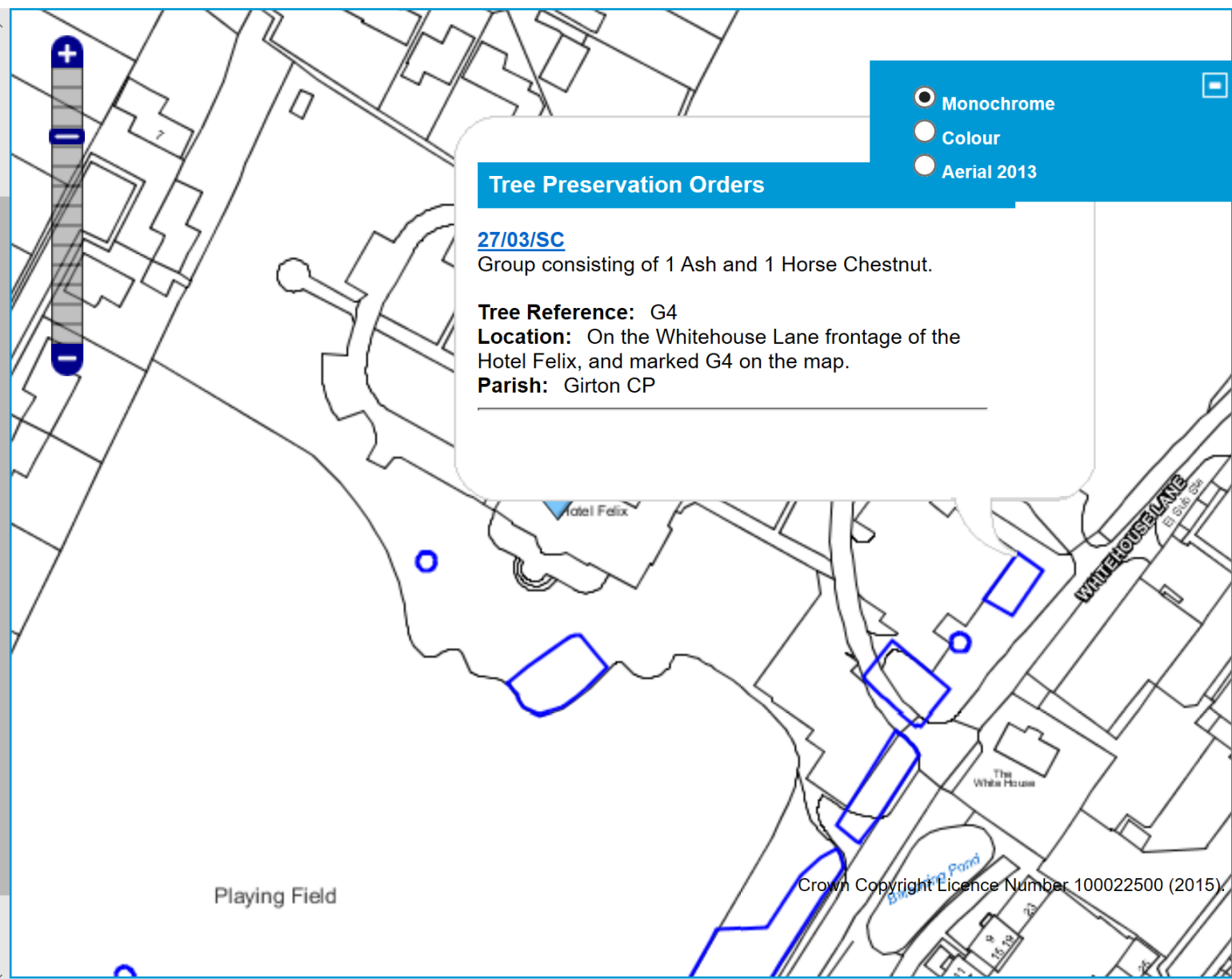

Tree Preservation Orders

- Tree Preservation Order
  - Region
  - Region
- ▶ Listed Buildings
- ▼ Conservation Areas 
  - Conservation Area
- ▶ Development Frameworks
- ▶ Parishes
- ▶ Green Belt

Search by Planning Reference

Find

Search for an Address

hotel felix

Find

Hotel Felix Whitehouse Lane (  )

Find

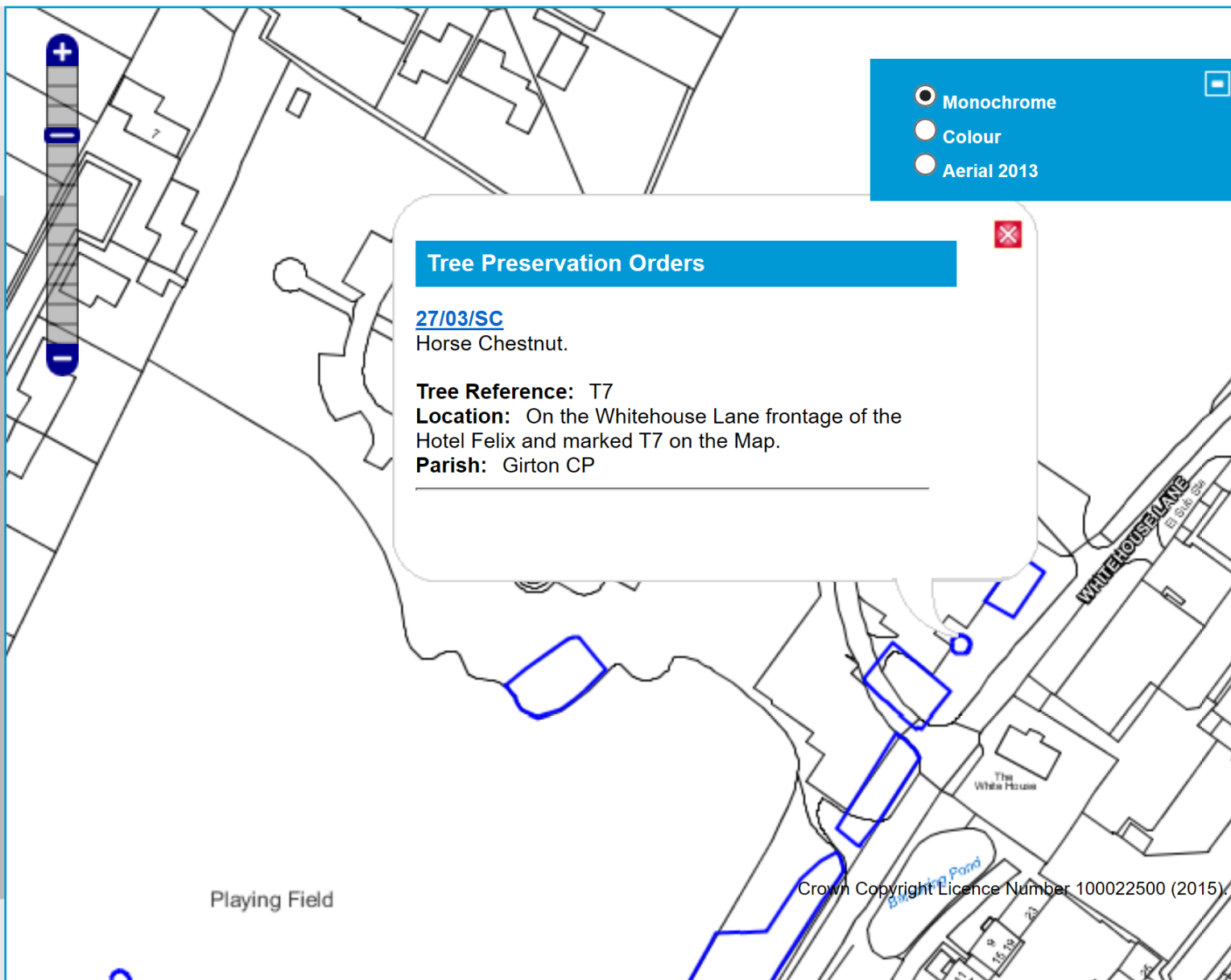

Tree Preservation Orders

- Tree Preservation Order
  - Region
  - Region
- ▶ Listed Buildings
- ▼ Conservation Areas 
  - Conservation Area
- ▶ Development Frameworks
- ▶ Parishes
- ▶ Green Belt

Search by Planning Reference

Find

Search for an Address

hotel felix

Find

Hotel Felix Whitehouse Lane (  )

Find

Monochrome  
 Colour  
 Aerial 2013

**Tree Preservation Orders**

[27/03/SC](#)  
 Group consisting of 1 Walnut, 1 Maple and 1 Horse Chestnut.

**Tree Reference:** G3  
**Location:** On the Whitehouse Lane frontage of the Hotel Felix, and marked G3 on the map.  
**Parish:** Girton CP

Crown Copyright Licence Number 100022500 (2015)

Tree Preservation Orders

- Tree Preservation Order
  - Region
  - Region
- ▶ Listed Buildings
- ▼ Conservation Areas 
  - Conservation Area
- ▶ Development Frameworks
- ▶ Parishes
- ▶ Green Belt

Search by Planning Reference

Find

Search for an Address

Find

Find

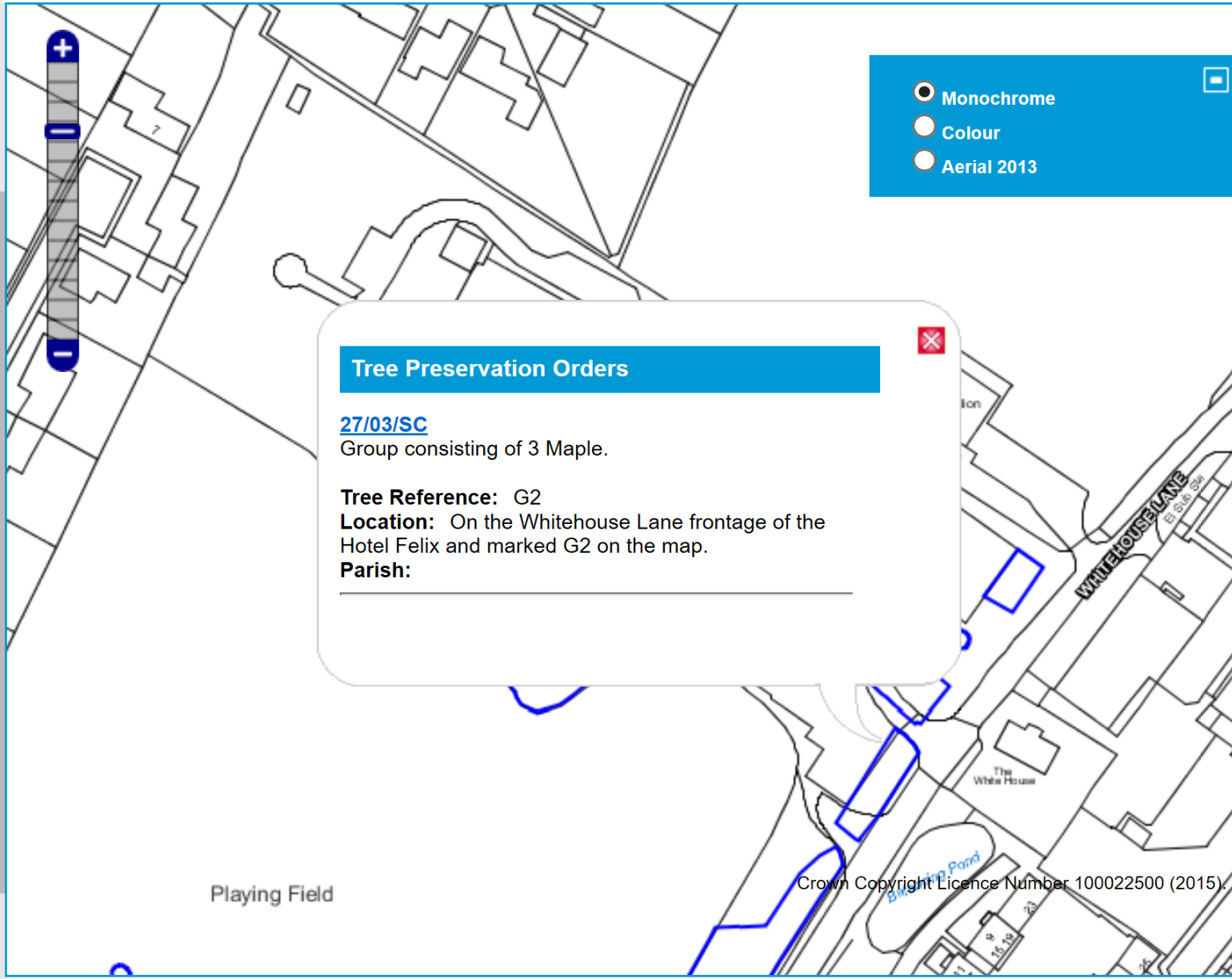

## **Appendix G**

Advisory Information & Sample Specifications

# 1. BS 5837:2012 Figure 1 - Flow Chart – Design and Construction & Tree Care

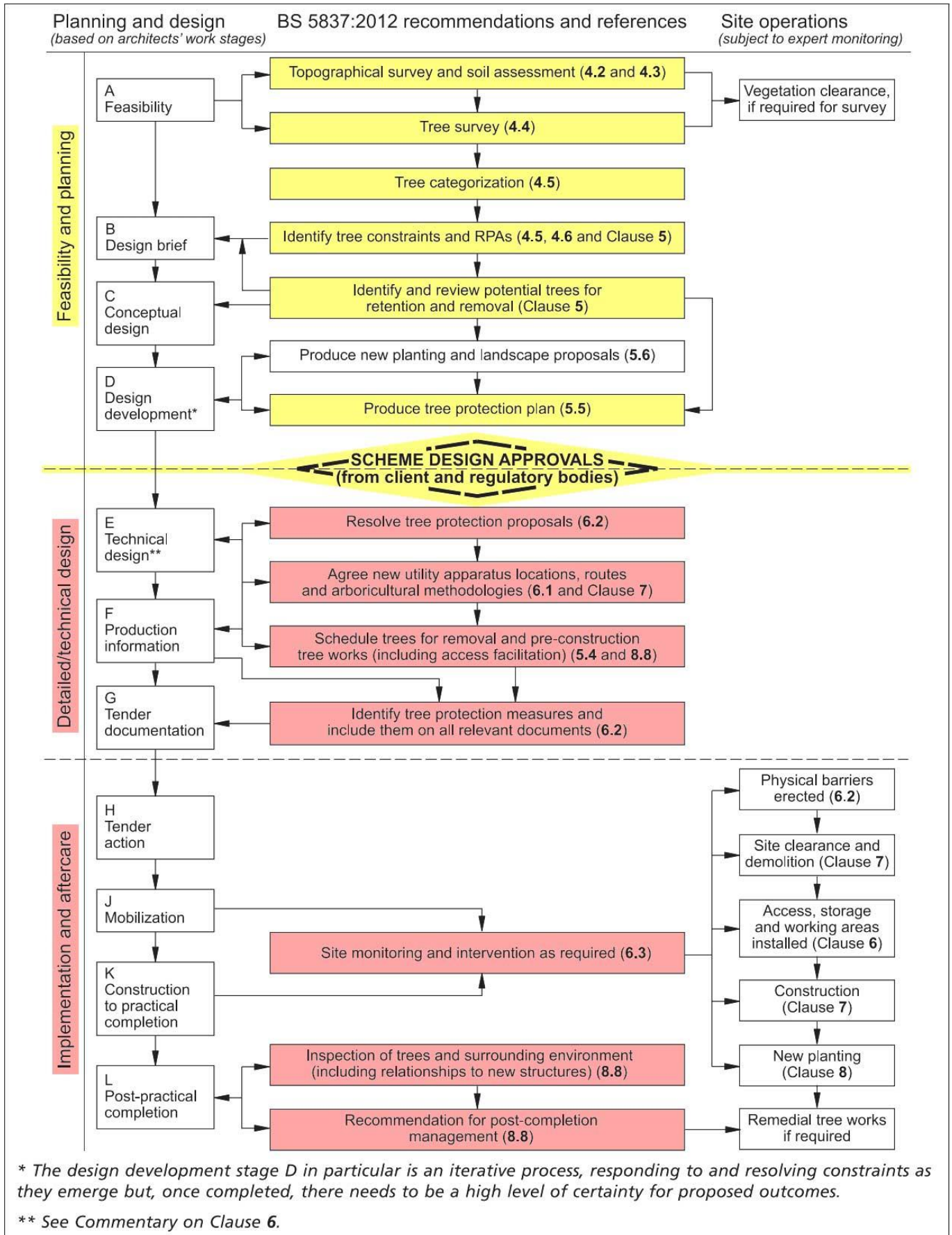

2.

**European Protected Species and woodland operations. (V4)**  
Complete all sections of the Checklist

Checklist		Details												
<b>1</b>	<p>Are you within, or close to, the known mapped range of any of the protected species OTHER THAN BATS which are potentially everywhere? Tick any that apply. See distribution maps in the Good Practice Guidance for each species -</p> <ul style="list-style-type: none"> <li><input type="checkbox"/> Dormice</li> <li><input type="checkbox"/> Otters</li> <li><input type="checkbox"/> Great crested newts</li> <li><input type="checkbox"/> Sand lizards</li> <li><input type="checkbox"/> Smooth snakes</li> </ul>	<p>Name of Wood:</p> <hr/> <p>Grid Reference:</p> <table border="1" style="width: 100%; height: 20px; border-collapse: collapse;"> <tr> <td style="width: 25%;"></td> <td style="width: 25%;"></td> <td style="width: 25%;"></td> <td style="width: 25%;"></td> </tr> </table> <p>Area: (ha)</p> <table border="1" style="width: 100%; height: 20px; border-collapse: collapse;"> <tr> <td style="width: 25%;"></td> <td style="width: 25%;"></td> <td style="width: 25%;"></td> <td style="width: 25%;"></td> </tr> </table> <p>Date of Assessment:</p> <table border="1" style="width: 100%; height: 20px; border-collapse: collapse;"> <tr> <td style="width: 25%;"></td> <td style="width: 25%;"></td> <td style="width: 25%;"></td> <td style="width: 25%;"></td> </tr> </table> <p>Name of Assessor:</p> <hr/>												
<b>2</b>	<p>Does your wood contain any of the following habitats? Tick any that apply.</p> <ul style="list-style-type: none"> <li><input type="checkbox"/> Old trees with holes and crevices which might be used bats</li> <li><input type="checkbox"/> Species rich scrub/coppice, early growth stage plantations and forest interfaces</li> <li><input type="checkbox"/> Rivers on which otters might be found</li> <li><input type="checkbox"/> Ponds which might be occupied by great crested newts</li> <li><input type="checkbox"/> Open areas on heathy soils</li> </ul>	<p>YES</p> <p>NO</p>												
<b>3</b>	<p>Have any of the protected species been recorded in this wood or on adjoining sites? Tick any that apply. Indicate which sources of information you have checked:</p> <ul style="list-style-type: none"> <li><input type="checkbox"/> National Biodiversity Network (<a href="http://www.nbn.org.uk">www.nbn.org.uk</a>)</li> <li><input type="checkbox"/> Local Biological Records Centre</li> <li><input type="checkbox"/> Local Wildlife Trust</li> <li><input type="checkbox"/> Other</li> </ul> <p>Specify Other:</p>	<p>YES</p> <p>NO</p>												
<b>4</b>	<p>Have your inspections or any expert surveys found any of the following signs or evidence? Tick any that apply.</p> <ul style="list-style-type: none"> <li><input type="checkbox"/> Signs (e.g. otter spraint, nuts gnawed by dormice, leaves folded by newts)</li> <li><input type="checkbox"/> Sightings (or echo-location)</li> <li><input type="checkbox"/> Potential breeding or roosting sites (e.g. veteran trees, old trees with crevices, riverside hollow trees, ponds, timber stacks, large fallen deadwood)</li> <li><input type="checkbox"/> Confirmed breeding or roosting sites (i.e. evidence of sites actually being used)</li> </ul> <p>Details:</p>	<p>YES</p> <p>NO</p>												
<b>CHECK POINT</b>	<p>If you have answered NO to ALL of the above then only bats need to be considered in your operations.</p> <p>If you have answered YES to any of the above then the species concerned must be considered as well as bats.</p>													
<b>5</b>	<p>Do the operations comply with Good Practice for bats and any other species found (or likely to be found in your wood) or can the operations be modified to do so? <i>Details: Use reverse of form to expand as required.</i></p>	<p>YES</p> <p>NO</p>												
<b>6</b>	<p><u>Whether or not a licence is required...</u> Has the information been communicated to operators (including the location of breeding sites and sensitive areas)? Tick any that apply.</p> <ul style="list-style-type: none"> <li><input type="checkbox"/> Included in documentation (e.g. contract, letter of instruction, site assessment or other management plan)</li> <li><input type="checkbox"/> Shown to operators and/or their supervisor</li> <li><input type="checkbox"/> Marked with paint or hazard tape</li> <li><input type="checkbox"/> Shown on the site plan</li> </ul> <p>Other means:</p>	<p>YES</p> <p>NO</p>												
<b>7</b>	<p>Have arrangements for supervision been made to ensure Good Practice guidance is complied with during the operations? <i>Details:</i></p>	<p>YES</p> <p>NO</p>												
		<b>Notes</b>												
		<p>A licence is not required but continue to sections 6 and 7 below</p> <p>You will need to obtain a licence BEFORE carrying out the work (see EPS Licence Application Forms and Notes)</p>												
		<p>You may commit an offence if you do not tell your operators about the protected species in your wood.</p>												
		<p>You may commit an offence if you do not take steps to ensure that your operators comply with the Good Practice guidance.</p>												



3. BS 5837:2012 Figure 2: Default specification for protective barrier

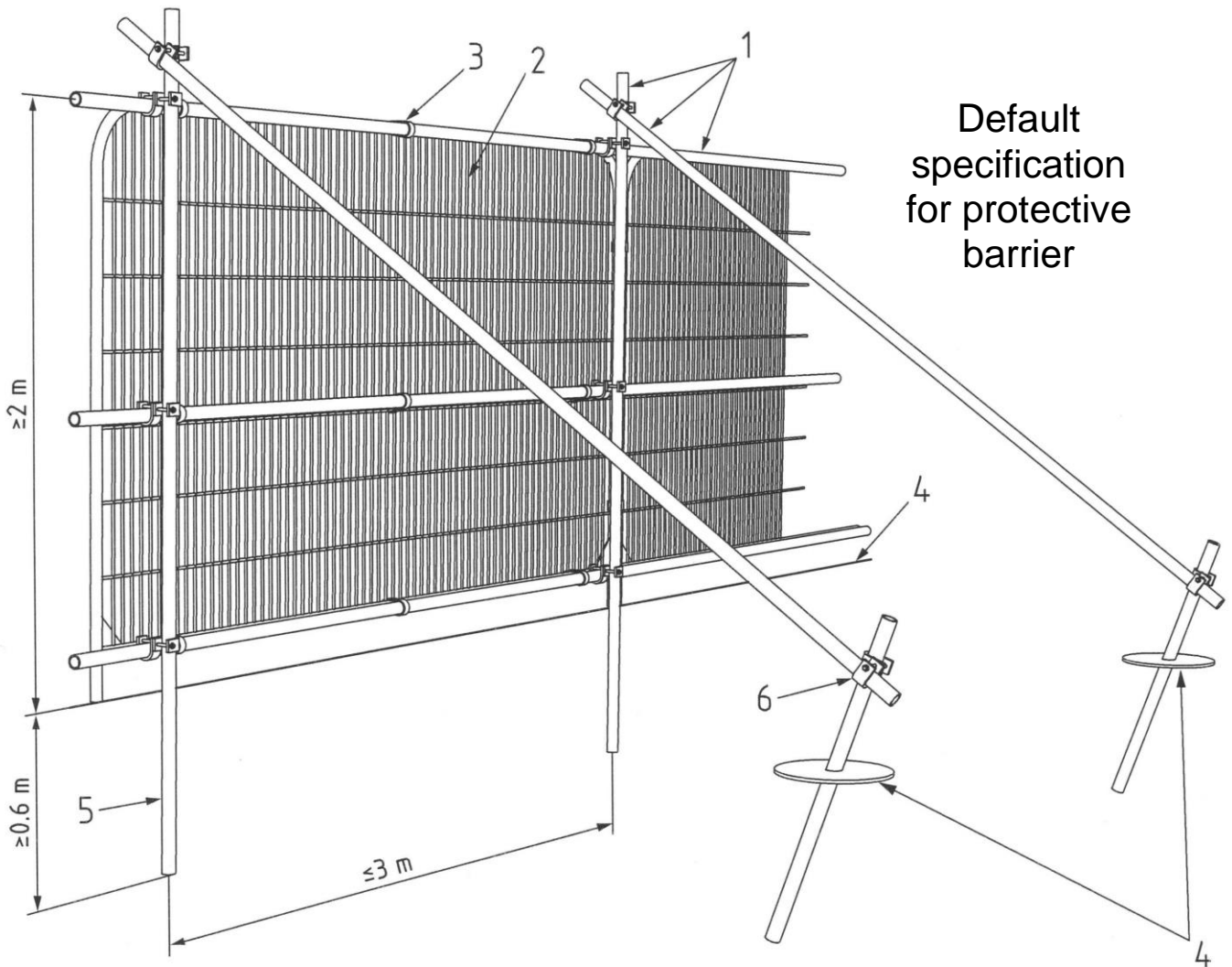

Default  
specification  
for protective  
barrier

Key

- 1 Standard scaffold pole
- 2 Heavy gauge 2m tall galvanised tube and welded mesh infill panels
- 3 Panels secured to uprights and cross-members with wire ties
- 4 Ground level
- 5 Uprights driven into the ground until secure (minimum depth 0.6m)
- 6 Standard scaffold clamps

4. BS 5837:2012 Figure 3: Examples of above-ground stabilizing systems

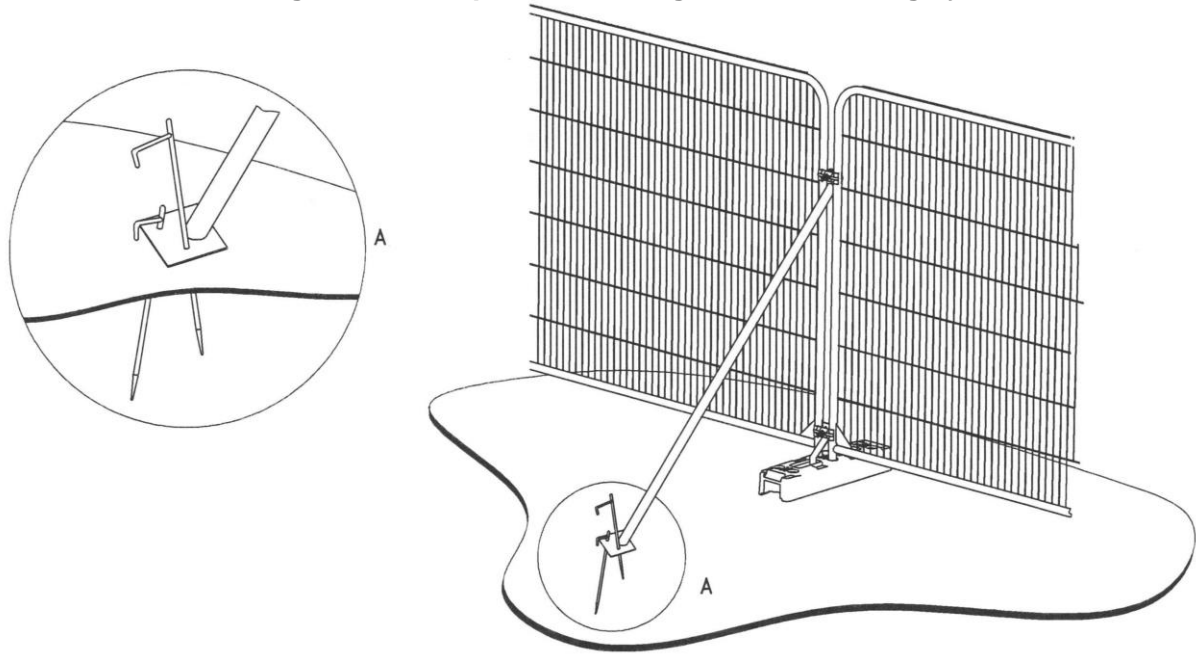

a) Stabilizer strut with base plate secured with ground pins

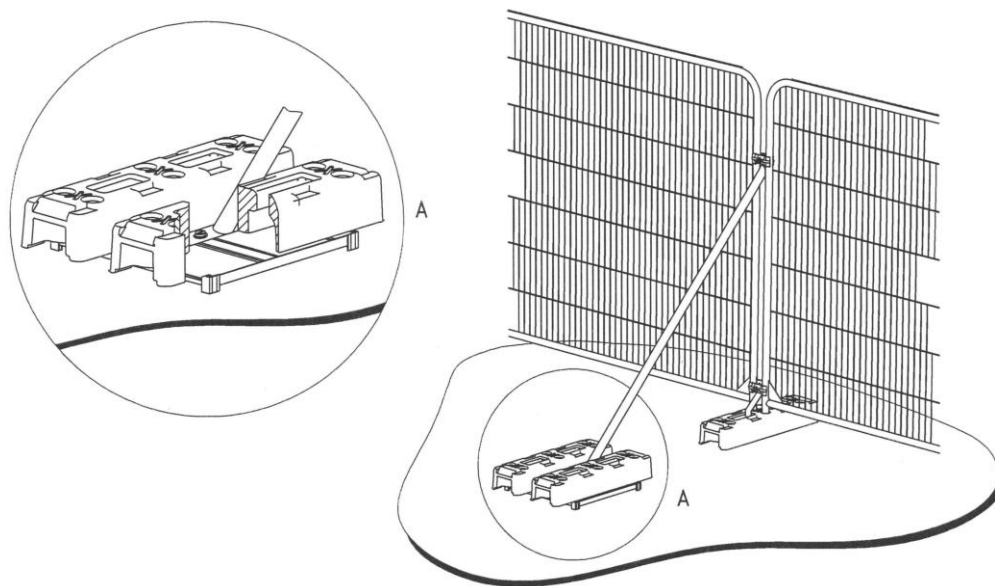

b) Stabilizer strut mounted on block tray

## **Appendix H**

Hayden's Drawing

- Arboricultural Impact Assessments ●
- Arboricultural Method Statements ●
- Tree Constraints Plans ●
- Arboricultural Feasibility Studies ●
- Shade Analysis ●
- Picus Tomography ●
- Arboricultural Consultancy for Local Planning Authority ●
- Quantified Tree Risk Assessment ●
- Health & Safety Audits for Tree Stocks ●
- Tree Stock Survey and Management ●
- Mortgage and Insurance Reports ●
- Subsidence Reports ●
- Woodland Management Plans ●
- Project Management ●
- Ecological Surveys ●



Telephone  
01284 765391  
Email  
[info@treesurveys.co.uk](mailto:info@treesurveys.co.uk)  
Website  
[www.treesurveys.co.uk](http://www.treesurveys.co.uk)

5 Moseley's Farm  
Business Centre  
Fornham All Saints  
Bury St Edmunds  
Suffolk  
IP28 6JY